



**iMdi**<sup>®</sup>



# ÍNDICE/por productos

*pie*

HiHat  
**HH01 / HH22**



HiHat  
**HH11**  
mediana



HiHat  
**HH18**  
m. translúcida



HiHat  
**HH03**  
grande



HiHat  
**HH20**  
g. translúcida



Cavia  
**CV10**



Charles  
**CH03**

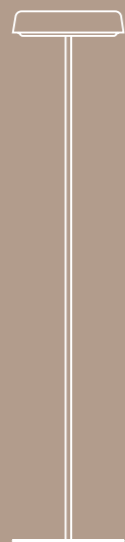

Arco  
**AR01**

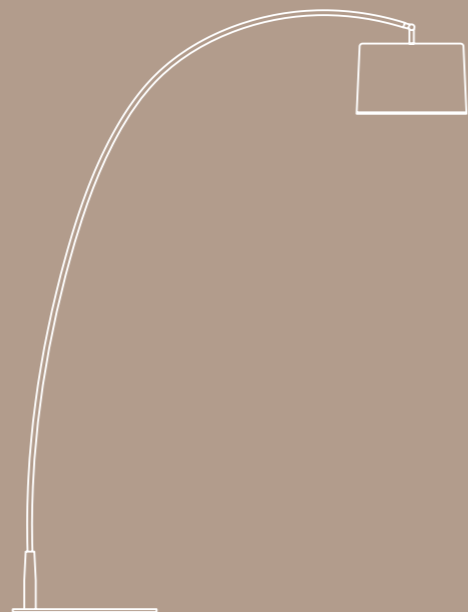

*mesa*

HiHat  
**HH04**  
chica



HiHat  
**HH09**  
p. translúcida



HiHat  
**HH12**  
p. translúcida  
alta



HiHat  
**HH21**  
p. mediana



HiHat  
**HH07**  
p. grande

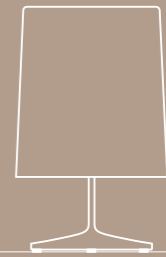

Tokio  
**TK01**



Cavia  
**CV02**



# ÍNDICE/por productos

## colgante

HiHat  
**HH02**  
plato



HiHat  
**HH23**  
plato grande

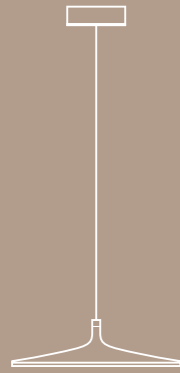

HiHat  
**HH05**  
chica



HiHat  
**HH10**  
c. translúcida



HiHat  
**HH08**  
mediana



HiHat  
**HH17**  
m. translúcida



Charles  
**CH02**



Shade  
**SH01 / SH04**  
**SH14 / SH24**  
chica



Shade  
**SH02 / SH03**  
**SH13 / SH23**  
grande



Roma  
**RM04**



Roma  
**RM05**

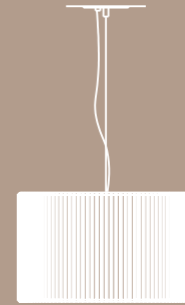

Aero  
**AE02**  
plafón chico

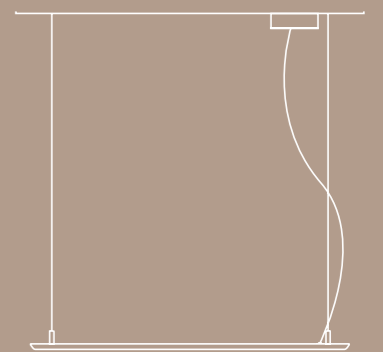

HiHat  
**HH06**  
grande

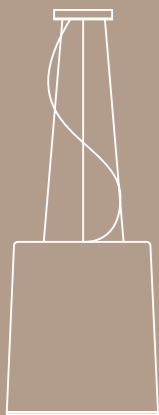

HiHat  
**HH19**  
g. translúcido



Cavia  
**CV01**  
16



Cavia  
**CV03**  
24



Cavia  
**CV04**  
48



Puma vertical  
**PM05 / PM06**



Puma  
**PM01 / PM02**

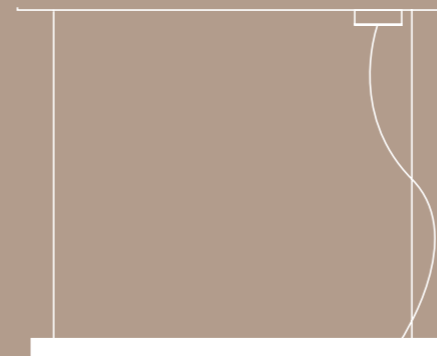

Masterline  
**ML01 / ML02**



Tokio  
**TK02 / TK03**

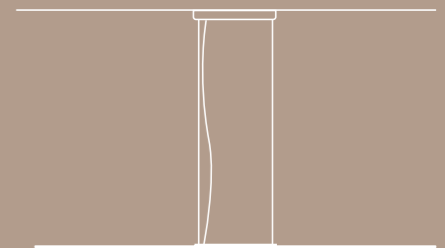



*pie*

**iMdi.**

---

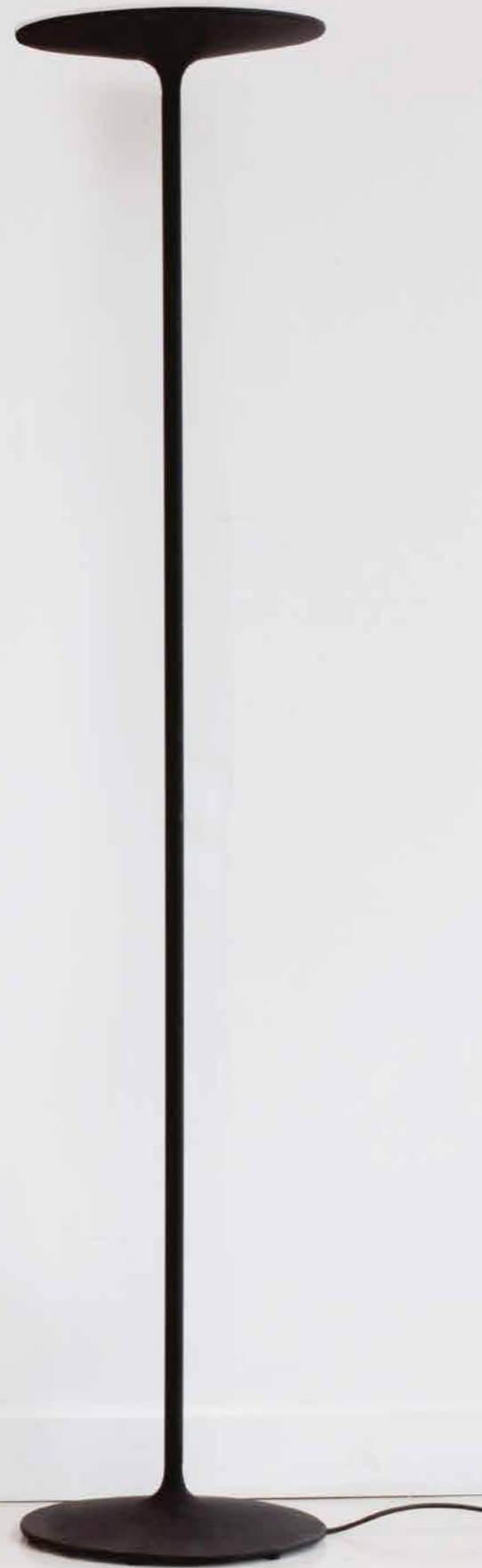

## HiHat de pie

Martín Wolfson - Martín Freijo



**HH01-02 - Dimerizable**  
**HH22-02 - On-Off**  
blanco  
microtexturado semimate

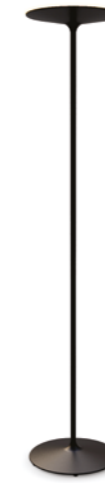

**HH01-03 - Dimerizable**  
**HH22-03 - On-Off**  
negro  
microtexturado semimate

Lámpara de pie

Luz indirecta

Base, pie y pantalla de aluminio

Difusor de acrílico blanco opalino

On-Off: Cable alimentación 1,5m negro o blanco con interruptor de piso

Dimerizable: Cable alimentación 1,5m negro o blanco con dimerizador por pulsos

Base con bumpers de elastómero negro

**Placas Led 31,5W / Flujo 4950 lm**

**3000 K / CRI 80**

**Fuente incorporada I<sub>max</sub> 700 mA 220-240v**

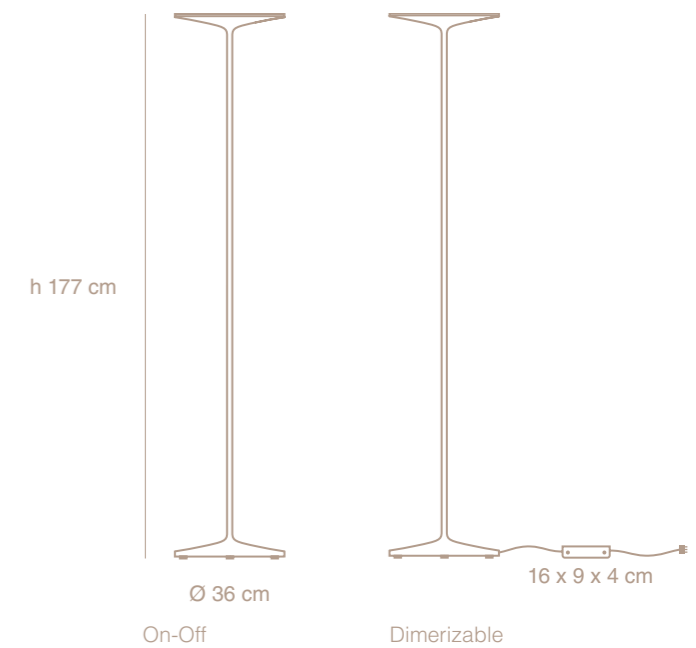

HiHat  
de pie

BuenDiseño

iMdi®



# HiHat

de pie - mediana

Martín Wolfson - Martín Freijo



**HH11-02**  
blanco  
microtexturado semimate



**HH11-03**  
negro  
microtexturado semimate

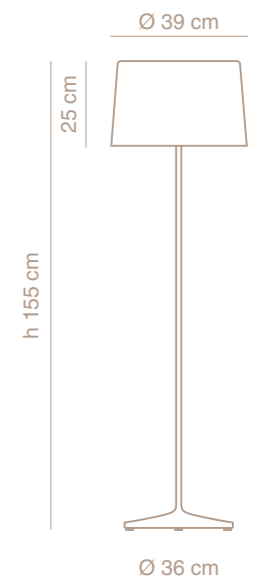

Lámpara de pie con pantalla

Luz directa

Base, pie y pantalla de aluminio

Difusor de acrílico blanco opalino

Cable alimentación 1,5m negro o blanco con interruptor de piso on/off

Base con bumpers de elastómero negro

3 x Max 36w - E27/ 220v

**HiHat**  
de pie - mediana







**HiHat**  
de pie - mediana translúcida

## HiHat

de pie - mediana translúcida

Martín Wolfson - Martín Freijo



**HH18-02**  
blanco  
microtexturado semimate



**HH18-03**  
negro  
microtexturado semimate

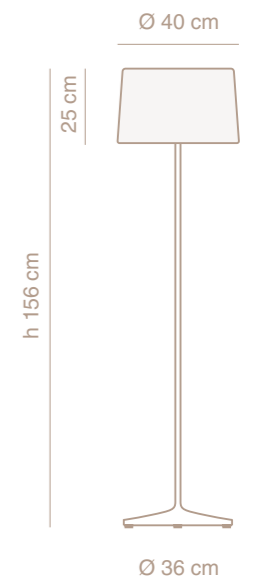

Lámpara de pie con pantalla

Luz directa

Base y pie de aluminio

Pantalla PE blanco opalino

Cable alimentación 1,5m negro o blanco con interruptor de piso on/off

Base con bumpers de elastómero negro

Max 1 x Max 60w - E27 / 220v





# HiHat de pie - grande

Martín Wolfson - Martín Freijo



**HH03-02**  
blanco  
microtexturado semimate



**HH03-03**  
negro  
microtexturado semimate

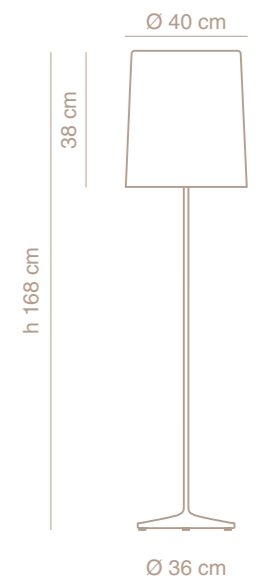

Lámpara de pie con pantalla

Luz directa

Base, pie y pantalla de aluminio

Difusor de acrílico blanco opalino

Cable alimentación 1,5m negro o blanco con interruptor de piso on/off

Base con bumpers de elastómero negro

3 x Max 36 w - E27/ 220v

**HiHat**  
de pie - grande





# HiHat

de pie - grande translúcida

Martín Wolfson - Martín Freijo



**HH20-02**  
blanco  
microtexturado semimate



**HH20-03**  
negro  
microtexturado semimate

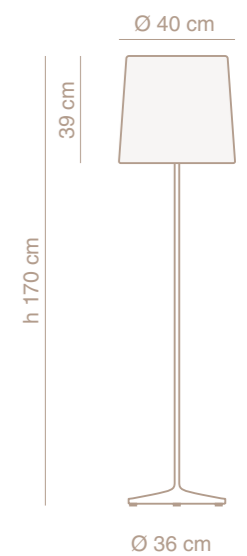

Lámpara de pie con pantalla

Luz directa

Base y pie de aluminio

Pantalla PE blanco opalino

Cable alimentación 1,5m negro o blanco con interruptor de piso on/off

Base con bumpers de elastómero negro

1 x Max 60w - E27 / 220v

**HiHat**  
de pie - grande translúcida





Cavia  
de pie

## Cavia de pie

Martín Wolfson - Martín Freijo



**CV10-02**  
blanco  
semimate



**CV10-03**  
negro  
semimate

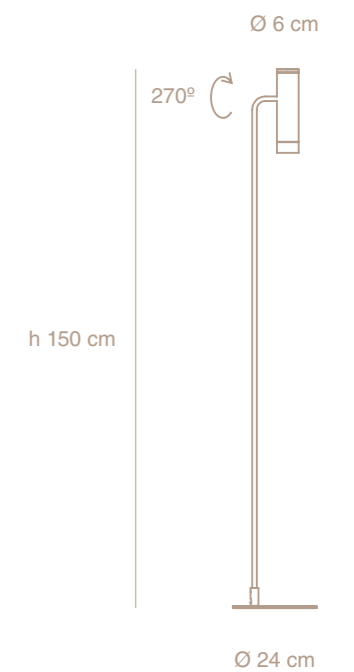

Lámpara de pie orientable, 270°

Luz directa direccional

Cabezal de aluminio mecanizado CNC

Base y pie metálico

Cable alimentación 1,5m negro o blanco on/off

Base con bumpers de elastómero negro

1x Max 10W LED Gu10





# Charles de pie

Martín Wolfson - Martín Freijo



**CH03-02**  
blanco  
microtexturado semimate



**CH03-03**  
negro  
microtexturado semimate

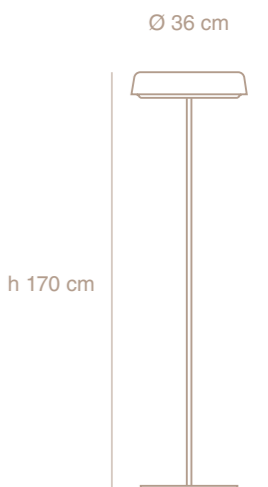

Lámpara de pie con pantalla

Luz directa

Base metálica, pie y pantalla de aluminio

Difusor de acrílico blanco opalino

Cable alimentación 1,5m negro o blanco con interruptor de piso on/off

Led 24v 16W / Flujo 1650 lm

2700 K / CRI 80

Fuente incorporada en cable de alimentación  
100-240v

Charles  
de pie

**iMdi**



Arco  
de pie

## Arco de pie

Martín Wolfson - Martín Freijo



**AR01-02**  
blanco  
microtexturado semimate

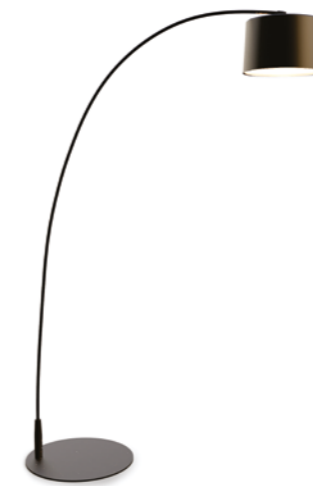

**AR01-03**  
negro  
microtexturado semimate

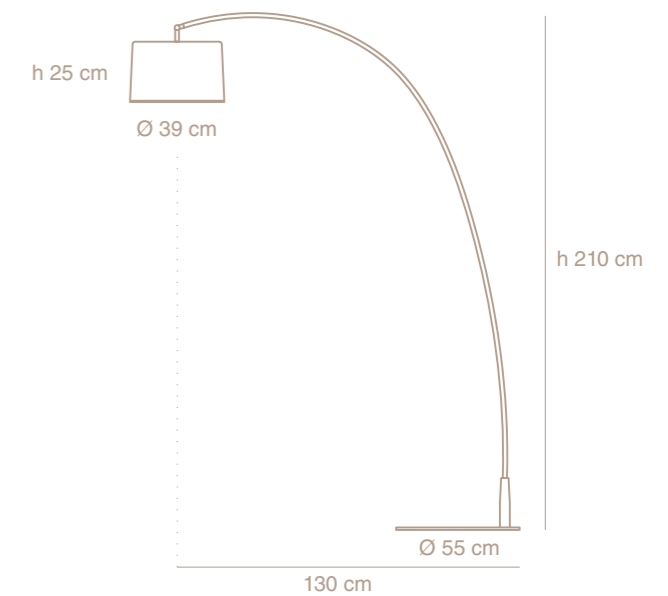

Lámpara de pie con pantalla

Luz directa

Pantalla de aluminio

Base y brazo metálico

Difusor de acrílico blanco opalino

Cable alimentación 1,5m negro o blanco con interruptor de piso on/off

Altura pantalla: 180 cm

1 x Max 60w - E27/ 220v

**iMdi**

mesa

iMdi.



# HiHat velador

Martín Wolfson - Martín Freijo



**HH04-02**  
blanco  
microtexturado semimate



**HH04-03**  
negro  
microtexturado semimate

Lámpara de mesa

Luz directa

Base, pie y pantalla de aluminio

Difusor de acrílico blanco opalino

Interruptor on/off

Base con bumpers de elastómero negro

1 x Max 36w - E27/ 220v

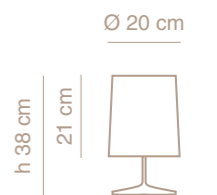

HiHat  
velador







# HiHat

velador translúcido

Martín Wolfson - Martín Freijo



**HH09-02 bajo**  
**HH12-02 alto**  
blanco  
microtexturado semimate



**HH09-03 bajo**  
**HH12-03 alto**  
negro  
microtexturado semimate

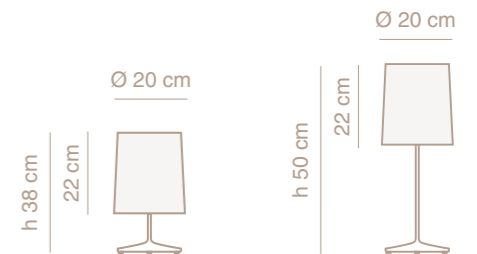

Lámpara de mesa

Luz directa

Base y pie de aluminio

Pantalla PE blanco opalino

Interruptor on/off

Base con bumpers de elastómero negro

1 x Max 36w - E27/ 220v

**HiHat**  
velador translúcido





# HiHat

de mesa - mediana

Martín Wolfson - Martín Freijo



**HH21-02**  
blanco  
microtexturado semimate



**HH21-03**  
negro  
microtexturado semimate

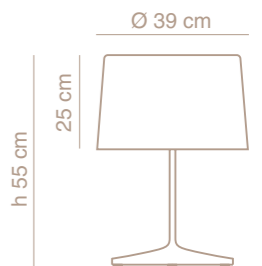

Lámpara de mesa

Luz directa

Base, pie y pantalla de aluminio

Difusor de acrílico blanco opalino

Interruptor de piso on/off

Base con bumpers de elastómero negro

1 x Max 60w - E27/ 220v

**HiHat**  
de mesa - mediana





# HiHat

de mesa - grande

Martín Wolfson - Martín Freijo



**HH07-02**  
blanco  
microtexturado semimate



**HH07-03**  
blanco  
microtexturado semimate

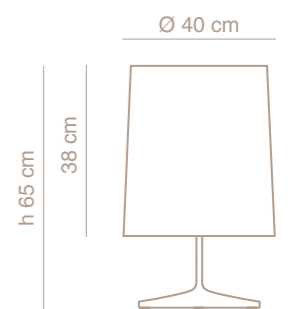

Lámpara de mesa

Luz directa

Base, pie y pantalla de aluminio

Difusor de acrílico blanco opalino

Interruptor de piso on/off

Base con bumpers de elastómero negro

1 x Max 60w - E27/ 220v

**HiHat**  
de mesa - grande





# Tokio escritorio

Martín Freijo



**TK01-02**  
blanco  
semimate



**TK01-03**  
negro  
semimate

Luz directa

Brazo de aluminio y acrílico blanco

Base metálica

Interruptor on/off

Led 24v 11,5W / Flujo 1200 lm

2700 K / CRI 80

Fuente incorporada en cable de  
alimentación 100-240v

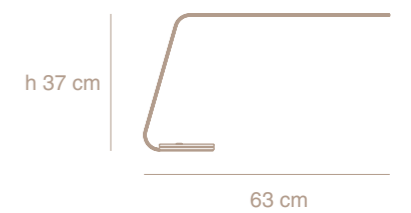

**Tokio**  
escritorio





## Cavia de mesa



**CV02-02**  
blanco  
semimate



**CV02-03**  
negro  
semimate

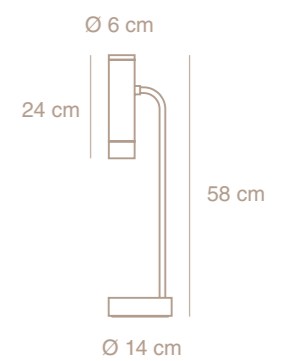

Lámpara mesa

Luz directa direccional orientable 270°

Cabezal de aluminio mecanizado CNC

Interruptor on/off

Cable alimentación 2m negro o blanco

1 x MAX 10w LED Gu10 - 220V

**Cavia**  
de mesa

**iMdi**®



*colgante* **iMdi.**



**HiHat**  
colgante plato

## HiHat colgante plato

*Martín Wolfson - Martín Freijo*



**HH02-02**  
blanco  
microtexturado semimate



**HH02-03**  
negro  
microtexturado semimate

Lámpara suspendida

Luz directa

Pantalla de aluminio

Difusor de acrílico blanco opalino

Cable de suspensión de acero inoxidable  
regulable

Cable transparente

Placas Led 22,4W / Flujo 3300 lm

3000 K / CRI 80

Fuente incorporada en florón cielorraso lmax  
700 mA 220- 240v

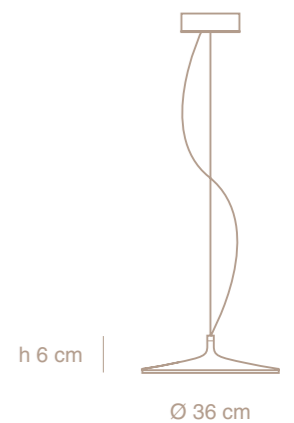



# HiHat

## colgante plato grande

Martín Wolfson - Martín Freijo



**HH23-02**  
blanco  
microtexturado semimate



**HH23-03**  
negro  
microtexturado semimate

Lámpara suspendida

Luz directa

Pantalla de aluminio

Difusor de acrílico blanco opalino

Cable blanco o negro

Caja porta driver de techo metálico terminación blanco o negro.

Placa Led 31,5W / Flujo 4950 lm

3000 K / CRI 80

Fuente incorporada en florón cielorraso lmax 700mA 220-240v

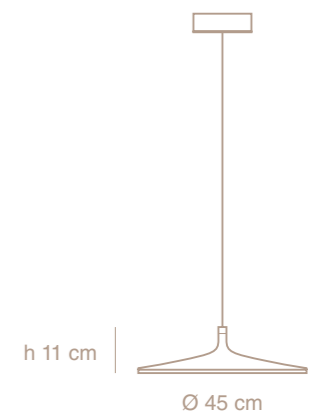

**HiHat**  
colgante plato grande







**HiHat**  
colgante chica

## HiHat colgante chica

Martín Wolfson - Martín Freijo



**HH05-02**  
blanco  
microtexturado semimate



**HH05-03**  
negro  
microtexturado semimate

accesorios sugeridos



plafón + derivadores

Lámpara suspendida

Luz directa

Pantalla de aluminio

Terminación blanco o negro microtexturado o  
anodizado natural

Difusor de acrílico blanco opalino

Cable de suspensión de acero inoxidable  
regulable

Cable transparente

1 x Max 36w E27 - 220V

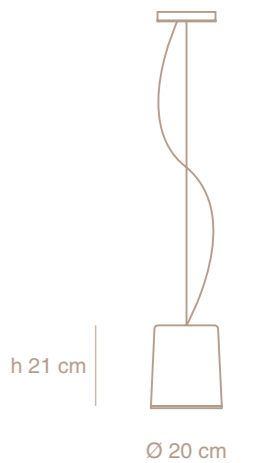



**HiHat**  
colgante chica translúcida

## HiHat

colgante chica translúcida

Martín Wolfson - Martín Freijo



**HH10-02**  
PE blanco opalino

accesorios sugeridos



plafón + derivadores

Lámpara suspendida

Luz directa

Cable de suspensión de acero inoxidable regulable

Cable transparente

1 x Max 36w E27 - 220V

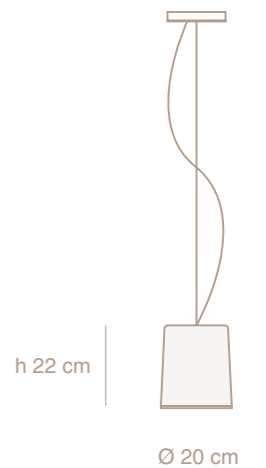

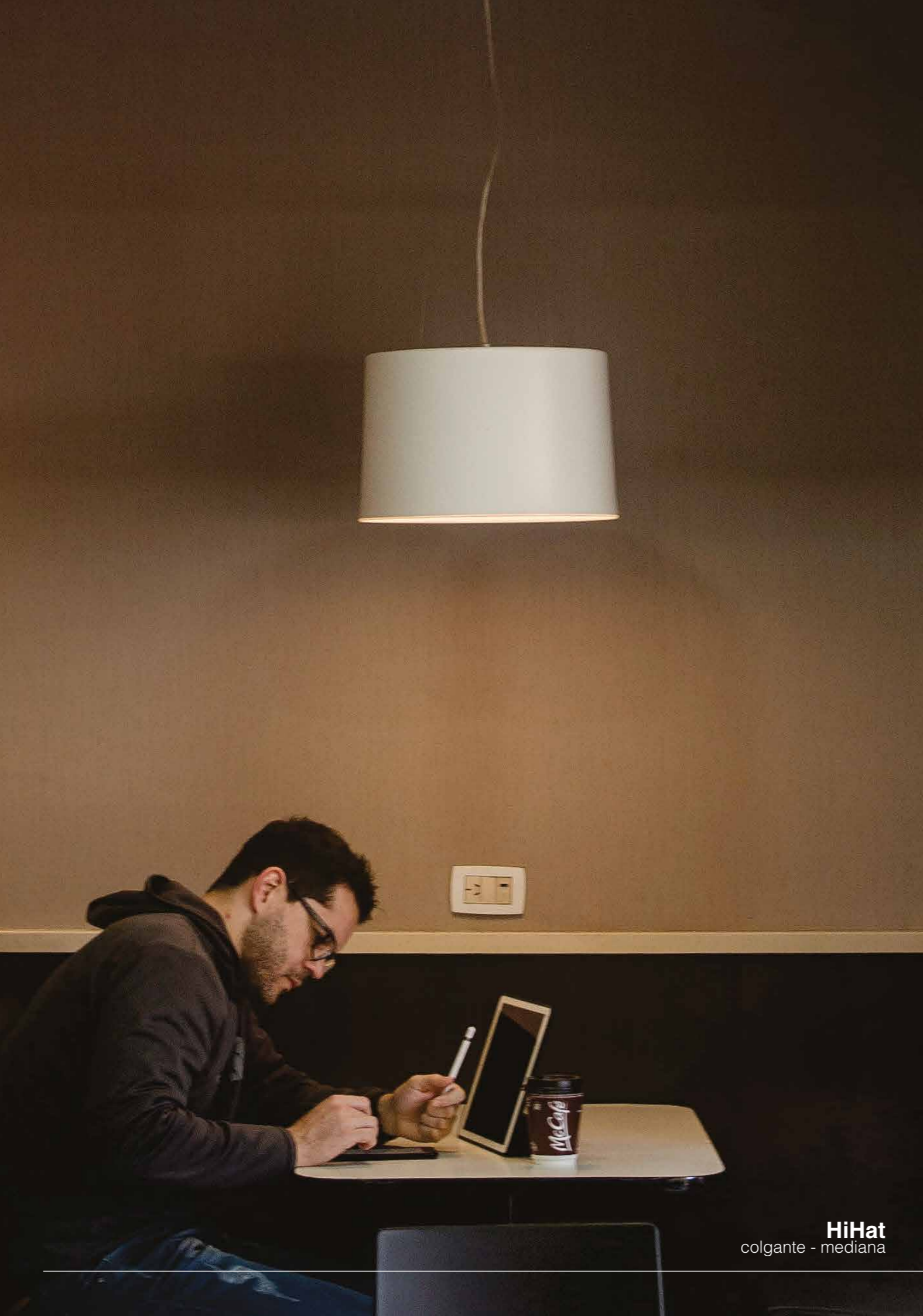

**HiHat**  
colgante - mediana

## HiHat colgante - mediana

Martín Wolfson - Martín Freijo



**HH08-02**  
blanco  
microtexturado semimate



**HH08-03**  
negro  
microtexturado semimate

Lámpara suspendida

Luz directa

Pantalla de aluminio

Terminación blanco o negro microtexturado o  
anodizado natural

Difusor de acrílico blanco opalino

3 cables de suspensión de acero inoxidable  
regulables

Cable transparente

1 x Max 60w E27 - 220V

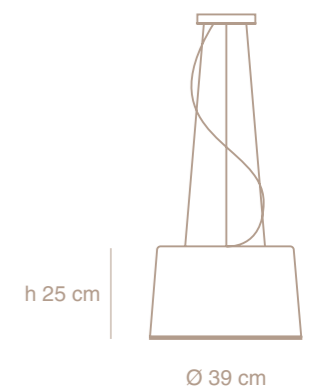



# HiHat

colgante - mediana translúcida

*Martín Wolfson - Martín Freijo*



**HH17-02**  
PE blanco opalino

- Lámpara suspendida
- Luz directa
- Pantalla de PE blanco opalino
- 3 cables de suspensión de acero inoxidable regulables
- Cable transparente
- 1 x Max 60w E27 - 220V

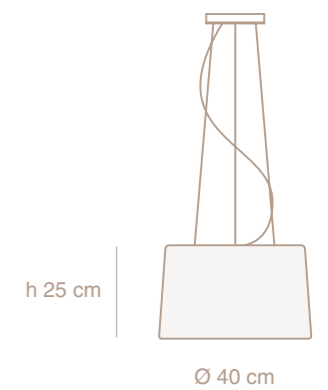

**HiHat**  
colgante - mediana translúcida





# HiHat

colgante - grande

Martín Wolfson - Martín Freijo



**HH06-02**  
blanco  
microtexturado semimate



**HH06-03**  
negro  
microtexturado semimate

Lámpara suspendida

Luz directa

Pantalla de aluminio

Terminación blanco o negro microtexturado o  
anodizado natural

Difusor de acrílico blanco opalino

3 cables de suspensión de acero inoxidable  
regulables

Cable transparente

1 x Max 60w E27 - 220V

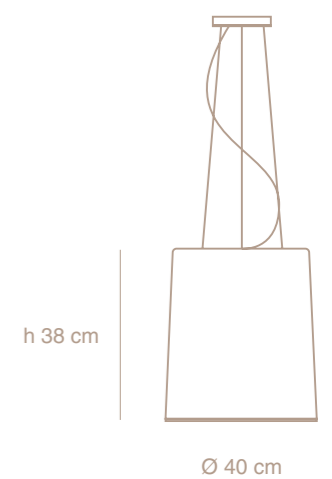

**HiHat**  
colgante - grande





# HiHat

colgante - grande translúcida

Martín Wolfson - Martín Freijo



**HH19-02**  
PE blanco opalino

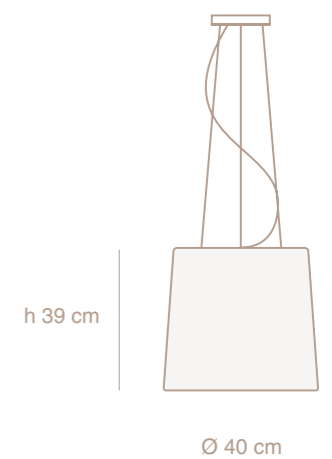

Lámpara suspendida

Luz directa

Pantalla de PE blanco opalino

3 cables de suspensión de acero inoxidable regulables

Cable transparente

1 x Max 60w E27 - 220V

**HiHat**  
colgante - grande translúcida





# Cavia

## colgante - 16

Martín Wolfson - Martín Freijo



**CV01-02**  
blanco  
semimate

**CV01-03**  
negro  
semimate

accesorios sugeridos



plafón 3 posiciones  
SC03-02 (blanco)  
SC03-03 (negro)



plafón  
SC04-02 (blanco)  
SC04-03 (negro)  
derivadores  
SC05-02 (aluminio)

Lámpara suspendida

Luz directa

Cuerpo de aluminio mecanizado CNC

Terminación blanco o negro semimate

Cable textil - long 1.5m

Apto intemperie (consultar)

1 x Max 10w LED Gu10

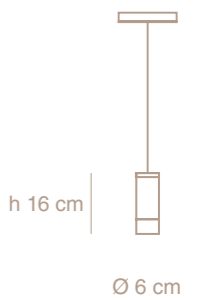

**Cavia**  
colgante - 16





# Cavia

## colgante - 24

Martín Wolfson - Martín Freijo



**CV03-02**  
blanco  
semimate

**CV03-03**  
negro  
semimate

accesorios sugeridos



plafón 3 posiciones  
SC03-02 (blanco)  
SC03-03 (negro)



plafón  
SC04-02 (blanco)  
SC04-03 (negro)  
derivadores  
SC05-02 (aluminio)

Lámpara suspendida

Luz directa

Cuerpo de aluminio mecanizado CNC

Terminación blanco o negro semimate

Cable textil - long 1.5m

Apto intemperie (consultar)

1 x Max 10w LED Gu10

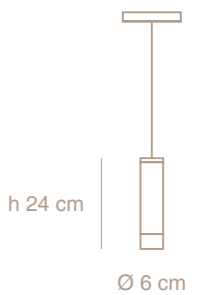

Cavia  
colgante - 24







# Cavia

## colgante - 48

Martín Wolfson - Martín Freijo



**CV04-02**  
blanco  
semimate



**CV04-03**  
negro  
semimate

### accesorios sugeridos



plafón 2 posiciones  
SC02-02 (blanco)



plafón 3 posiciones  
SC03-02 (blanco)



plafón  
SC04-02 (blanco)  
SC04-03 (negro)

derivadores  
SC05-02 (aluminio)

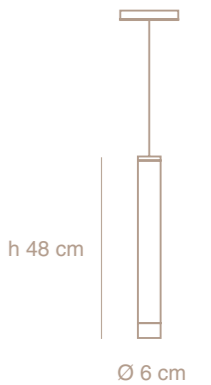

Lámpara suspendida

Luz directa

Cuerpo de aluminio mecanizado CNC

Terminación blanco o negro semimate

Cable textil - long 1.5m

Apto intemperie (consultar)

1 x Max 10w LED Gu10

Cavia  
colgante - 48





Charles  
colgante

## Charles colgante

Martín Wolfson - Martín Freijo



**CH02-02**  
blanco  
microtexturado semimate



**CH02-03**  
negro  
microtexturado semimate

Lámpara suspendida

Luz directa

Pantalla de aluminio

Difusor de acrílico blanco opalino

Cable de suspensión de acero inoxidable regulable

Cable transparente

Placa Led 18,9W / Flujo 3000 lm

3000 K / CRI 80

Fuente incorporada en florón cielorraso  
Imax 700 mA 220- 240v

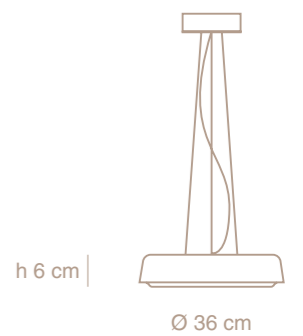

h 6 cm

Ø 36 cm

**iMdi**



Shade  
chica

# Shade chica

*Martín Wolfson - Martín Freijo - Juan Kayser - Darío Fischman*



**SH04-02 - E27**  
**SH14-02 - LED**  
exterior gris oscuro -  
interior gris claro

Lámpara suspendida

Luz directa

Estructura aluminio terminación negro  
microtexturado

Filtro acústico

Cable negro

**Modelo E27: 1 x Max 36W - 220V**

**Modelo LED: placa 31,5W / Flujo 4950 lm**  
3000 K / CRI 80

Fuente incorporada en florón cielorraso  
Imax 700mA 220-24v

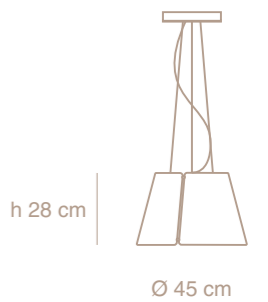



# Shade grande

*Martín Wolfson - Martín Freijo - Juan Kayser - Darío Fischman*



**SH03-02 - E27**  
**SH13-02 - LED**  
exterior gris oscuro -  
interior gris claro

Lámpara suspendida

Luz directa

Estructura aluminio terminación negro  
microtexturado

Filtro acústico

Cable negro

**Modelo E27: 1 x Max 36W - 220V**

**Modelo LED: placa 18,9W / Flujo 3000 lm**  
3000 K / CRI 80

Fuente incorporada en florón cielorraso  
Imax 700mA 220-24v

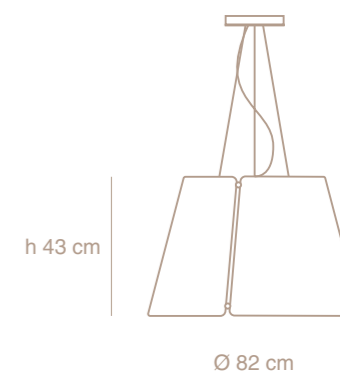

Shade  
grande



**iMdi**



Aero  
colgante

## Aero colgante

Martín Wolfson - Martín Freijo



**AE02-02**  
blanco  
microtexturado semimate

Lámpara suspendida

Luz indirecta

Base de acero inoxidable

Cable de suspensión de acero inoxidable  
regulable

Cable transparente

Led 24v 25,9W / 2700 lm

2700 K / CRI80

Fuente incorporada en florón cielorraso  
220-240v

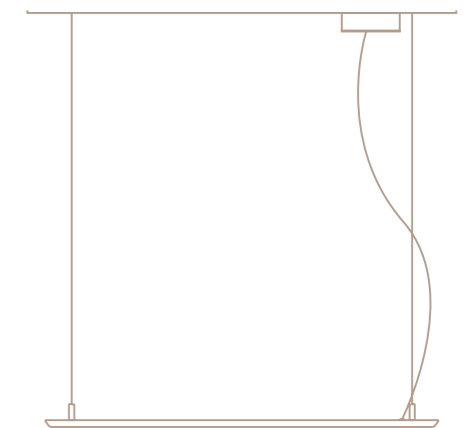

110 cm

**iMdi**®



# Puma colgante

Martín Wolfson - Martín Freijo



**PM01-02 / 120**  
**PM02-02 / 232**  
acrílico blanco  
blanco semimate

Lámpara suspendida

Luz directa

Cuerpo de plástico acrílico blanco opalino semi-  
mate

Cable de suspensión de acero Inoxidable regulable

Cable blanco

**Corto (120 cm): placa led 25,2W / Flujo 4000 lm**

**Largo (232 cm): placa led 50,4W / Flujo 8000 lm**

**3000 K / CRI 80**

Fuente incorporada en florón rectangular en el  
cielorraso 220-240v

Dimensiones florón: 33,5 x 3,5 x 4,2cm

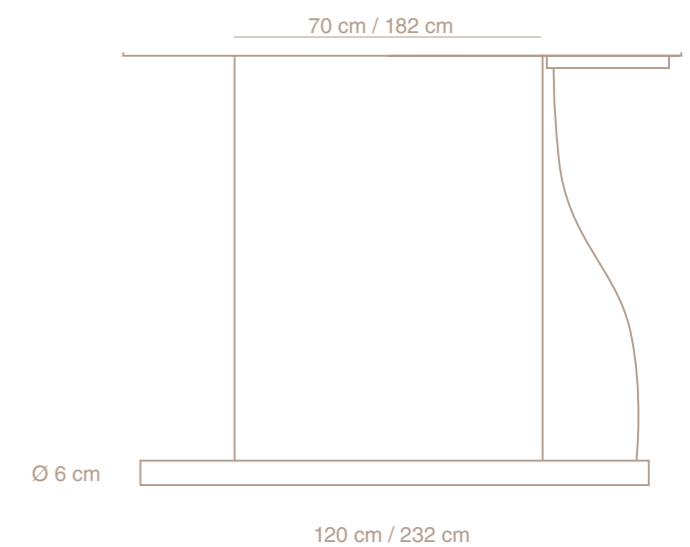

**Puma**  
colgante





**Puma**  
colgante vertical

## Puma colgante vertical

*Martin Wolfson - Bernard O'Connor*



**PM05-02 / 120**  
**PM06-02 / 65**  
acrílico blanco  
blanco semimate

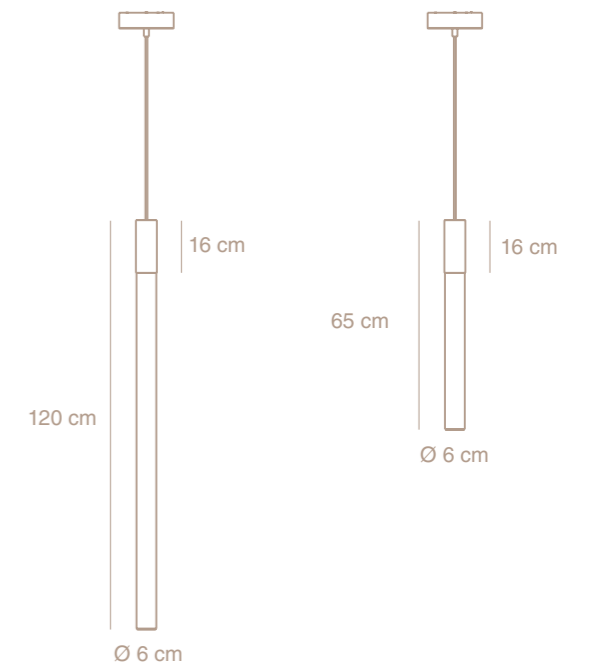

Lámpara suspendida

Luz directa

Cuerpo de aluminio y plástico acrílico blanco opalino  
semimate

Cable blanco

led 34v 12W / Flujo 1000 lm

3000 K / CRI 90

Fuente incorporada en florón cielorraso 220-240v

**iMdi**®



**Masterline**  
colgante

## Masterline colgante

Martín Wolfson - Martín Freijo



**ML01-02 / 180**  
**ML02-02 / 120**  
blanco  
semimate

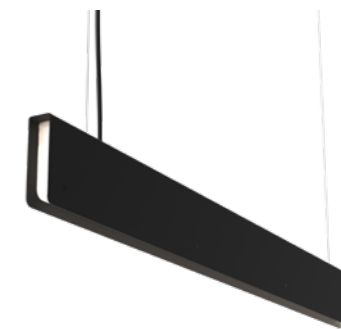

**ML01-03 / 180**  
**ML02-03 / 120**  
negro  
semimate

Lámpara suspendida

Luz directa

Cuerpo aluminio

Difusor acrílico blanco opalino

Cable de suspensión de acero inoxidable regulable

Cable blanco / negro

**Largo (180 cm): placa led 37.8W / flujo 6000 lm**

**Corto (120 cm): placa led 25.2W / flujo 4000 lm**

3000 K / CRI 80

Fuente incorporada en el artefacto 220-240v







Tokio  
colgante

## Tokio colgante



TK02-02 / 115  
TK03-02 / 170  
blanco  
semimate



TK02-03 / 115  
TK03-03 / 170  
negro  
semimate

Lámpara suspendida

Luz directa

Cuerpo aluminio

Difusor acrílico blanco opalino

Cable de suspensión de acero inoxidable regulable 1.5m

Cable blanco / negro

**Corto (115 cm): placa led 25.2W / flujo 4000 lm**

**Largo (170 cm): placa 37.8W led / flujo 6000 lm**

3000 K / CRI 80

Fuente incorporada en el florón cielorraso 220-240v

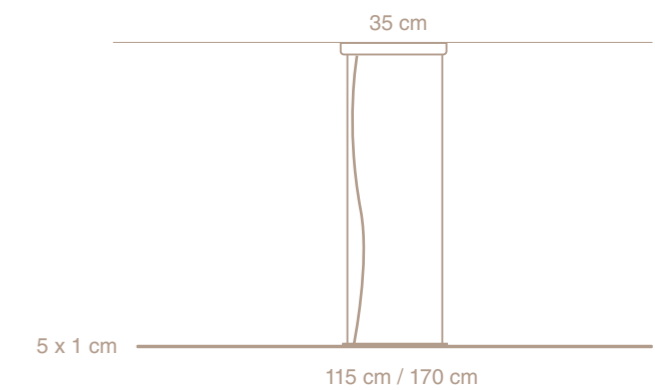

iMdi®



## Roma colgante

Martin Wolfson - Bernard O'Connor



**RM04-02**

exterior beige - interior claro



**RM04-03**

exterior gris oscuro - interior claro



**RM04-06**

exterior terracota - interior claro

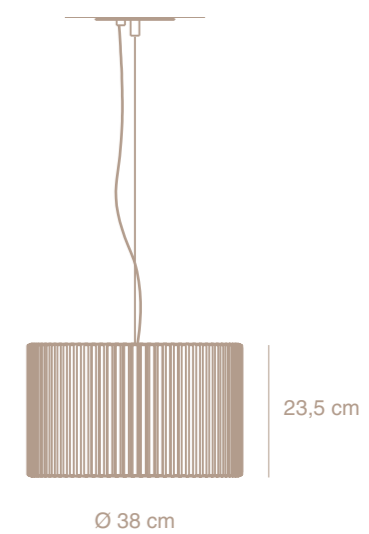

Lámpara suspendida

Luz directa

Estructura aluminio blanco microtexturado

Pantalla fieltro acústico

Cable de suspensión de acero inoxidable regulable 1.5m

Cable blanco

1 x Max 36w E27 - 220V

**iMdi**

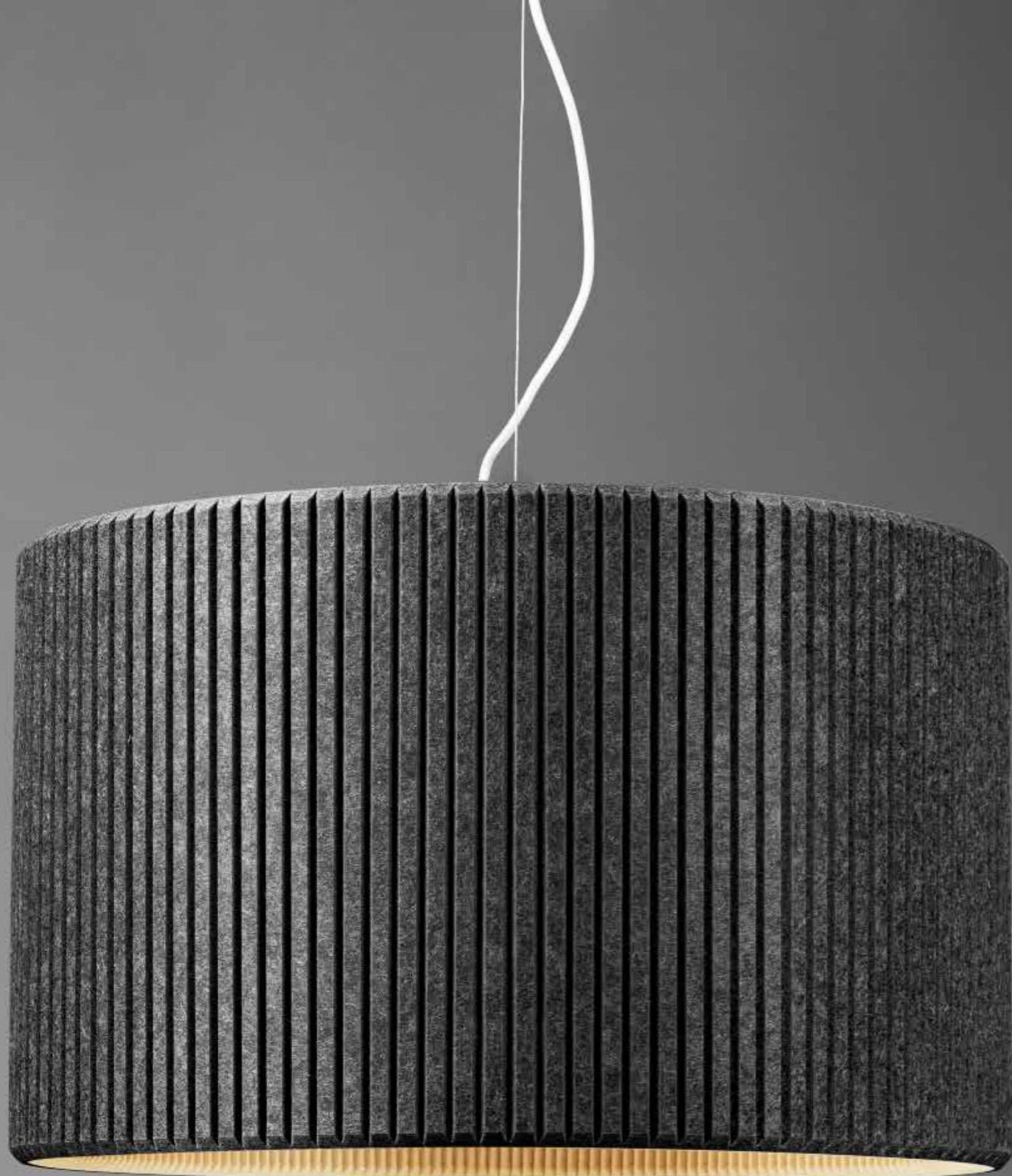

## Roma colgante

Martín Wolfson - Bernard O'Connor



**RM05-02**

exterior beige - interior claro

**RM05-03**

exterior gris oscuro - interior claro

**RM05-06**

exterior terracota - interior claro

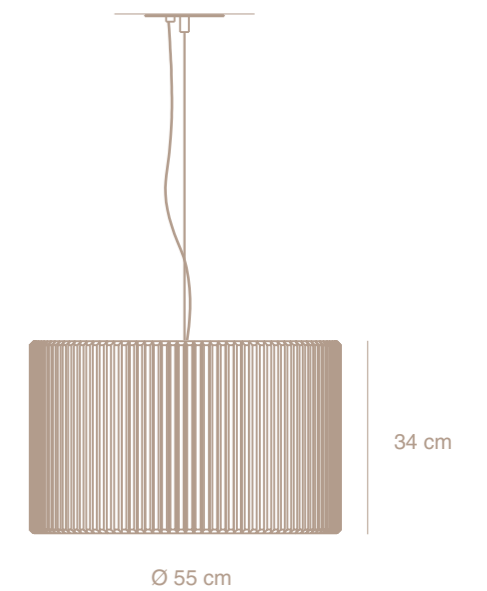

Lámpara suspendida

Luz directa

Estructura aluminio blanco microtexturado

Pantalla fieltro acústico

Cable de suspensión de acero inoxidable regulable 1.5m

Cable blanco

1 x Max 36w E27 - 220V

Roma  
colgante

**iMdi**®



*aplique*

**iMdi.**

---



**Charles**  
aplique / plafón

## Charles

aplique / plafón

Martín Wolfson - Martín Freijo



**CH01-02**  
blanco  
microtexturado semimate



**CH01-03**  
negro  
microtexturado semimate



Ø 36 cm



6 cm

Lámpara de pared o techo

Luz directa

Pantalla de aluminio

Difusor de acrílico blanco opalino

Placa Led 18,9W / Flujo 3000 lm

3000 K / CRI 80

Fuente incorporada I<sub>max</sub> 700 mA 220- 240v

**iMdi**®



# Puma applique

Martín Wolfson - Martín Freijo



**PM03-02 / 60**  
**PM04-02 / 120**  
acrílico blanco  
blanco semimate

Lámpara de pared o techo

Luz directa

Zócalo metálico

Difusor de acrílico blanco opalino

**Corto (60 cm): Placa led 12.6W / Flujo 2000 lm**

**Largo (120 cm): Placa led 25.2W / Flujo 4000 lm**

**3000 K / CRI 80**

**Fuente incorporada 220-240v**

Ø 6 cm



60/120 cm

10 cm

**Puma**  
applique





**Eclipse**  
aplique

## Eclipse aplique

Martín Wolfson - Martín Freijo



**EC01-02** / aluminio 60  
**EC02-02** / aluminio 45  
blanco  
semimate



**EC01-03** / aluminio 60  
**EC02-03** / aluminio 45  
negro  
semimate

accesorios

**SC06-02**  
separador 2 cm  
eclipse 60

**SC07-02**  
separador 2 cm  
eclipse 45

Lámpara de pared o techo

Luz directa

Cuerpo metálico

Perfil cilindrado con led de tensión constante

**Chica (45cm): led 12v 13W / Flujo 810 lm**

**Grande (60 cm): led 12v 20,3W / Flujo 1260 lm**

2700 K / CRI 80

Fuente incorporada 12V

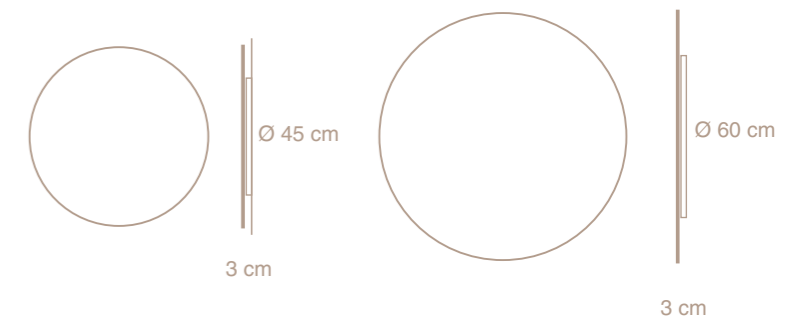



# Eclipse

## aplique

Martín Wolfson - Martín Freijo



**EC11-02** / fieltro 60  
**EC12-02** / fieltro 45  
gris  
claro



**EC11-03** / fieltro 60  
**EC12-03** / fieltro 45  
gris  
oscuro

accesorios

**SC06-02**  
separador 2 cm  
eclipse 60

**SC07-02**  
separador 2 cm  
eclipse 45

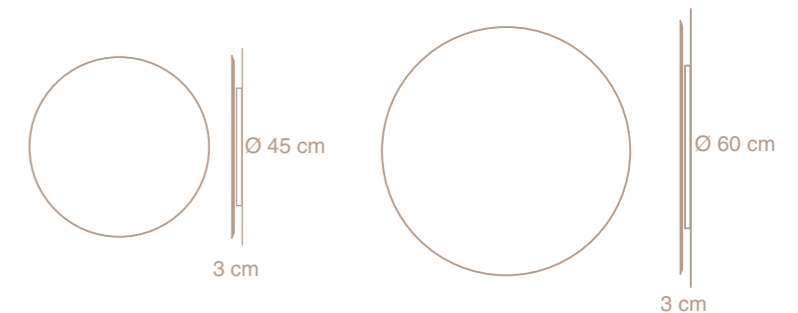

Lámpara de pared o techo

Luz directa

Cuerpo metálico y fieltro

Perfil cilindrado con led de tensión constante

**Chica (45cm): led 12v 13W / Flujo 810 lm**

**Grande (60 cm): led 12v 20,3W / Flujo 1260 lm**

**2700 K / CRI 80**

**Fuente incorporada 12V**

Eclipse fieltro  
aplique

**iMdi**®





## Eclipse stone applique

Martín Wolfson - Martín Freijo



**EC13-02** / fieltro grande  
**EC14-02** / fieltro chica  
gris  
claro



**EC13-03** / fieltro grande  
**EC14-03** / fieltro chica  
gris  
oscuro

accesorios

**SC06-02**  
separador 2 cm  
eclipse grande

**SC07-02**  
separador 2 cm  
eclipse chica

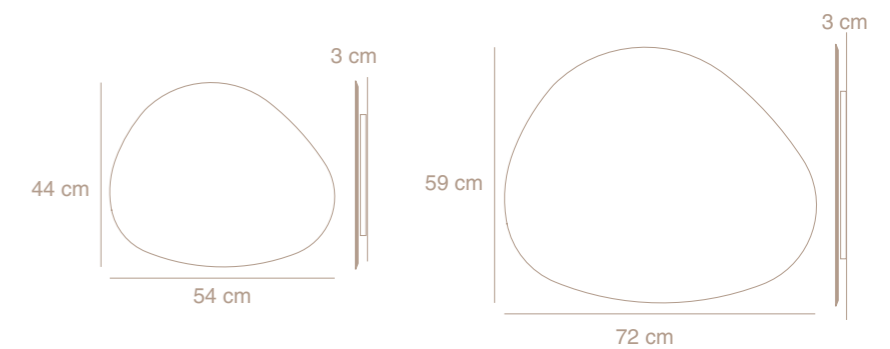

Lámpara de pared o techo

Luz directa

Cuerpo metálico y fieltro

Perfil cilindrado con led de tensión constante

**Chica (45cm): led 12v 13W / Flujo 810 lm**

**Grande (60 cm): led 12v 20,3W / Flujo 1260 lm**

**2700 K / CRI 80**

**Fuente incorporada 12V**

**Eclipse stone fieltro**  
applique

**iMdi**

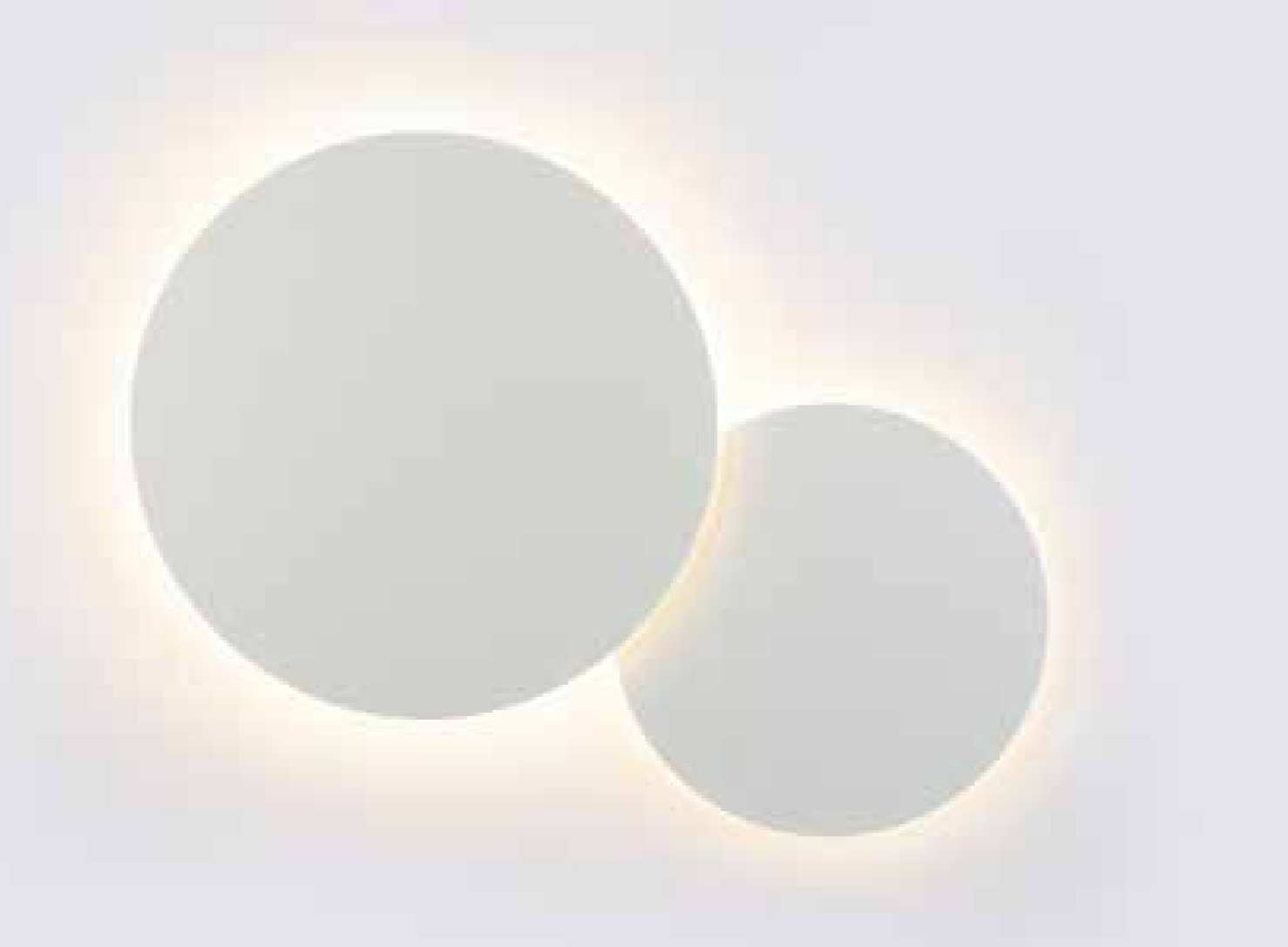

# Eclipse

## accesorio separador

Martín Wolfson - Martín Freijo

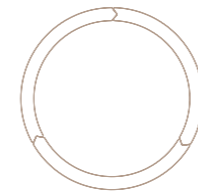

**SC06-02**  
separador  
eclipse grande

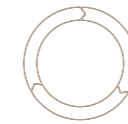

**SC07-02**  
separador  
eclipse chica

Ejemplos instalación

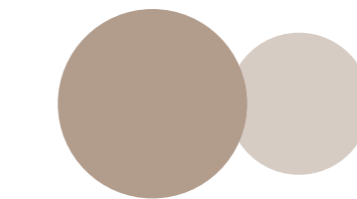

eclipse redonda x2

5 cm 3 cm

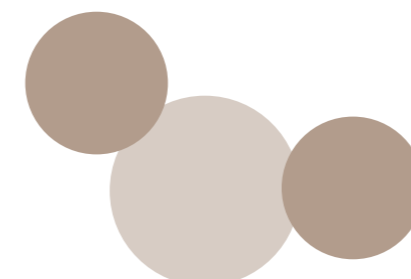
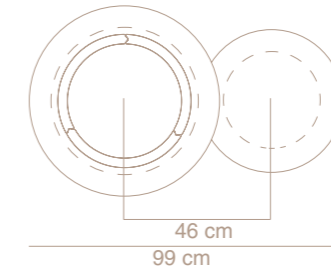

eclipse redonda x3

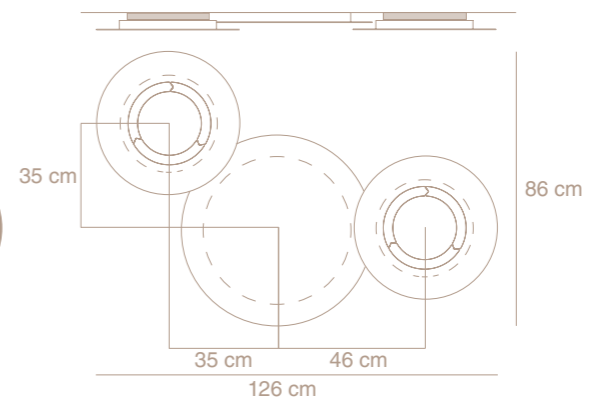

eclipse stone x2

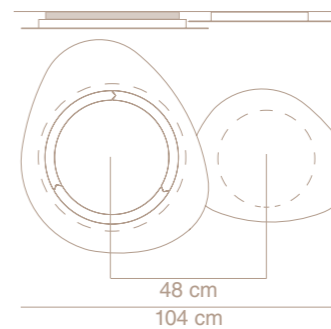

Eclipse  
accesorio separador



## Tokio

aplique - asimétrico



**TK04-02 / 95**  
blanco  
semimate

**TK04-03 / 95**  
negro  
semimate

Lámpara de pared  
Luz indirecta  
Cuerpo de aluminio  
Difusor de acrílico blanco opalino  
**placa led 12.6W / flujo 2000 lm**  
**3000K / CRI 80**  
**Fuente incorporada 220-240v**

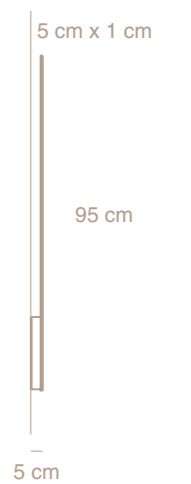

**Tokio**  
aplique - asimétrico

**iMdi®**



**Tokio**  
aplique - simétrico

## Tokio

aplique - simétrico



**TK05-02 / 150**  
blanco  
semimate

**TK05-03 / 150**  
negro  
semimate

Lámpara de pared  
Luz indirecta  
Cuerpo de aluminio  
Difusor de acrílico blanco opalino  
placa led 25.2W / flujo 4000 lm  
3000K / CRI 80  
Fuente incorporada 220-240v

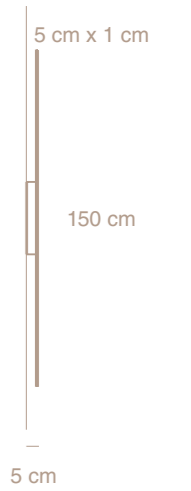



# Cavia

aplique - 16 unidireccional

*Martín Wolfson - Martín Freijo*



**CV05-02**  
blanco  
semimate



**CV05-03**  
negro  
semimate

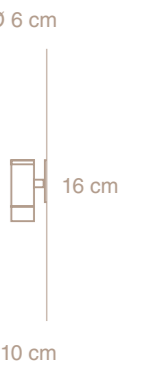

Lámpara de pared  
Luz directa unidireccional  
Cuerpo de aluminio mecanizado CNC  
Placa fijación metálica  
1 x Max 10w LED Gu10 - 220V

**Cavia**  
aplique - corto unidireccional





# Cavia

aplique - 24 unidireccional

*Martín Wolfson - Martín Freijo*



**CV06-02**  
blanco  
semimate



**CV06-03**  
negro  
semimate

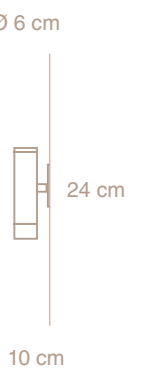

Lámpara de pared  
Luz directa unidireccional  
Cuerpo de aluminio mecanizado CNC  
Placa fijación metálica  
1 x Max 10w LED Gu10 - 220V

**Cavia**  
aplique - largo unidireccional





# Cavia

aplique - 25 bidireccional

Martín Wolfson - Martín Freijo



**CV07-02**  
blanco  
semimate



**CV07-03**  
negro  
semimate

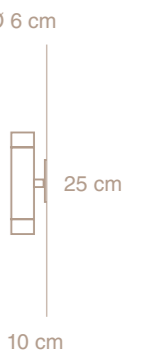

**Cavia**  
aplique - largo bidireccional

Lámpara de pared  
Luz directa bidireccional  
Cuerpo de aluminio mecanizado CNC  
Placa fijación metálica  
1 x Max 10w LED Gu10 - 220V





# Cavia

## brazo corto

Martín Wolfson - Martín Freijo



CV11-02 / cable  
CV21-02 / a caja  
blanco  
semimate



CV11-03 / cable  
CV21-03 / a caja  
negro  
semimate

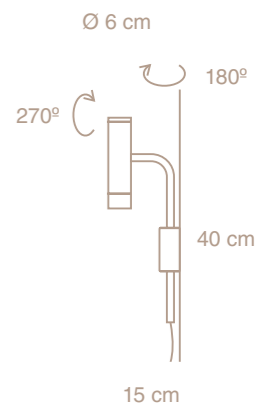

Lámpara de pared orientable 270°  
Luz directa unidireccional  
Cuerpo de aluminio mecanizado CNC  
Brazo basculante  
Modelo con cable e interruptor de mano on/off  
Modelo con conexión a caja sin interruptor  
1 x Max 10w LED Gu10 - 220V

Cavia  
brazo corto







# Cavia

## brazo largo

Martín Wolfson - Martín Freijo



**CV12-02** / cable  
**CV22-02** / a caja  
blanco  
semimate



**CV12-03** / cable  
**CV22-03** / a caja  
negro  
semimate



Lámpara de pared orientable 270°

Luz directa unidireccional

Cuerpo de aluminio mecanizado CNC

Brazo basculante de 120 cm de largo

Modelo con cable e interruptor de mano on/off

Modelo con conexión a caja sin interruptor

1 x Max 10w LED Gu10 - 220V

Cavia  
brazo largo





Cavia  
plafón - 16

# Cavia

## plafón - 16

Martín Wolfson - Martín Freijo



CV08-02  
blanco  
semimate



CV08-03  
negro  
semimate

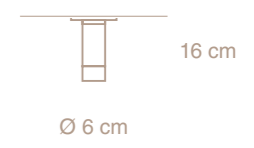

- Lámpara de techo
- Luz directa unidireccional
- Cuerpo de aluminio mecanizado CNC
- Placa fijación metálica
- 1 x MAX 10w LED Gu10 - 220V





# Cavia

## plafón - 24

Martín Wolfson - Martín Freijo



**CV09-02**  
blanco  
semimate



**CV09-03**  
negro  
semimate

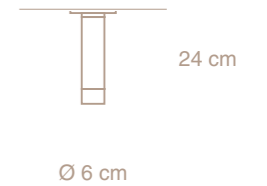

Lámpara de techo  
Luz directa unidireccional  
Cuerpo de aluminio mecanizado CNC  
Placa fijación metálica  
1 x MAX 10w LED Gu10 - 220V

Cavia  
plafón - 24





Cavia  
plafón - 48

## Cavia plafón - 48

Martín Wolfson - Martín Freijo



CV15-02  
blanco  
semimate



CV15-03  
negro  
semimate

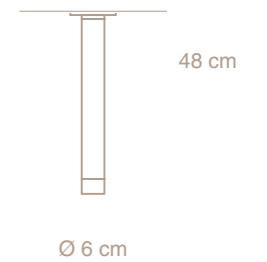

Lámpara de techo

Luz directa unidireccional

Cuerpo de aluminio mecanizado CNC

Placa fijación metálica

1 x MAX 10w LED Gu10 - 220V





**Cavia**  
spot corto / largo

## Cavia

spot 16 / 24

Martín Wolfson - Martín Freijo



**CV13-02**  
**CV14-02**  
blanco  
semimate



**CV13-03**  
**CV14-03**  
negro  
semimate

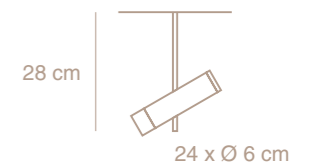
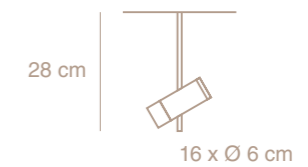

Lámpara de techo

Luz directa unidireccional

Cuerpo de aluminio mecanizado CNC

Detalles en aluminio torneado

1 x MAX 10w LED Gu10 - 220V



## Consejos útiles tipos de luz

<p><b>luz indirecta</b></p>  <p>HH01</p>	<ul style="list-style-type: none"> <li>La iluminación indirecta se adapta a cualquier estilo de decoración, <b>no interfiere ni compite</b> con los objetos del área a iluminar.</li> <li>La parte inferior cerrada permite que entre el 90 y 100 % del flujo luminoso se oriente verticalmente y se distribuye en el ambiente por difracción.</li> <li>Es importante que el techo o pared sea de <b>color claro</b>. Idealmente blanco.</li> <li>Genera <b>ambientes agradables</b>, con luz suave, regulable mediante un atenuador (dimmer).</li> <li>No produce sombras. Se recomienda con elevada reproducción cromática.</li> <li>Niveles de iluminación sugeridos: 150 a 200 lux. Cálida de 2770 a 3000 K.</li> <li>Uso en: <b>livings, recepciones, pasillos y espacios amplios.</b></li> </ul>
<p><b>luz semidirecta</b></p>  <p>CV07</p>	<ul style="list-style-type: none"> <li>Son los artefactos que iluminan en forma <b>bidireccional</b>.</li> <li>Verticalmente puede ser directa en una proporción de entre 60 y 80% del flujo.</li> <li>Dependiendo del diseño y las características del difusor varían las proporciones de flujo luminoso.</li> <li>Niveles recomendados: 100 a 150 lux para <b>pasillos</b> y entre 150 y 250 para <b>locales y ambientes grandes</b>.</li> <li>Color cálido: 2700 a 3000K . Puede ser frío en <b>áreas de circulación</b> o locales.</li> </ul>
<p><b>luz directa</b></p>  <p>TK01</p>  <p>CH01</p>	<ul style="list-style-type: none"> <li>Se recomienda cuando es necesario <b>focalizar un área</b> u objeto determinado.</li> <li>Las áreas pueden ser de trabajo o para el desarrollo de <b>actividades específicas</b>.</li> <li>La intensidad depende básicamente de las características de la fuente y por ser focalizada es importante ubicar correctamente las luminarias.</li> <li>La funcionalidad y la estética están dadas por el diseño del artefacto.</li> <li>Se debe considerar el <b>comfort visual</b>. Evitar encadilamientos y sensación de claridad total o deslumbramientos. Los contrastes producen cansancio visual.</li> <li>En lugares de trabajo no es recomendable usar lámparas de techo.</li> </ul>
 <p>AR01</p>  <p>PM01</p>	<ul style="list-style-type: none"> <li>En iluminación <b>residencial</b> se recomienda luz cálida (2700 a 3000K).</li> <li>En <b>espacios comerciales</b> y de <b>trabajo</b> luz fría.</li> <li>La intensidad lumínica varía según la aplicación.</li> </ul> <p>Residencias:</p> <ul style="list-style-type: none"> <li>En <b>dormitorios</b> es necesario proyectar varios tipos de <b>iluminación</b>. Una general para ambientar y otras directas para lectura, vestidor y escritorio.</li> <li>En <b>baños</b> se debe evitar iluminar arriba del espejo. Se recomienda colocar artefactos tipo apliques a la altura de los ojos. Reproducción cromática alta.</li> <li>En <b>cocinas</b> las áreas de trabajo con luz directa de 4000K y complementar con indirecta cálida.</li> <li>En <b>comedores</b> considerar el <b>comfort visual</b>, evitar deslumbramientos y luz ambiental cálida.</li> <li>Otros parámetros de referencia (en lux): en espacios de circulación 100, lectura 300, escritura y manualidades 500.</li> </ul> <p>Oficinas y áreas de trabajo:</p> <p>Halls 200, Oficinas 500, trabajos especiales 750, salones 300 y áreas de circulación 200.</p>

## Sistemas de colgado

Permiten el colgado de los artefactos de iluminación en diferentes configuraciones: simple, doble, triple, entre otros.



### Bandeja universal regulable

<p><b>Especificaciones técnicas</b></p> <p>Bandeja de chapa plegada con ranura central</p> <p>110 x 14 cm</p>	<p><b>Terminaciones</b></p> <p>Microtexturado blanco</p> <p>Microtexturado negro</p>	<p><b>Código</b></p> <p>SC01-02</p> <p>SC01-03</p>
---	--	--



### Plafón 3 posiciones

<p><b>Especificaciones técnicas</b></p> <p>Plafón de chapa 42 x 14 cm</p>	<p><b>Terminaciones</b></p> <p>Microtexturado blanco</p> <p>Microtexturado negro</p>	<p><b>Código</b></p> <p>SC03-02</p> <p>SC03-03</p>
---	--	--

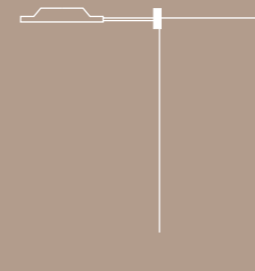

### Plafón ø 22 cm + Accesorio derivador

<p><b>Especificaciones técnicas</b></p> <p>Plafón ø 22 cm</p> <p>Accesorio derivador</p>	<p><b>Terminaciones</b></p> <p>Microtexturado blanco</p> <p>Microtexturado negro</p> <p>Aluminio natural</p>	<p><b>Código</b></p> <p>SC04-02</p> <p>SC04-03</p> <p>SC05-02</p>
--	--	---





**iMdi**<sup>®</sup>

**PROYECTOS**







hotelería

iMdi.



**The Brick Hotel**  
By Sofitel

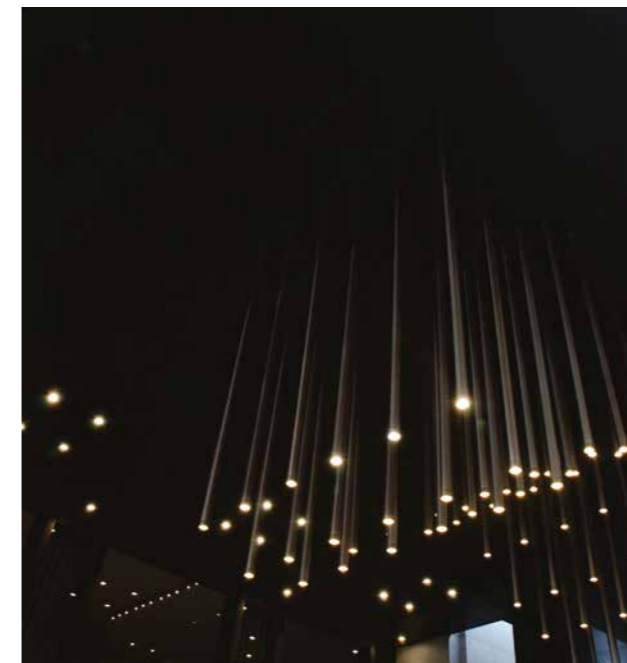

**iMdi**® **The Brick Hotel**  
By Sofitel

*Proyecto:* Rubinat - Arq. Patricio Olivares+

*Iluminadora:* Arq. Giuliana Nievas

*Año:* 2018

*Ubicación:* Posadas 1232 (CABA, Argentina)



Cavia especial

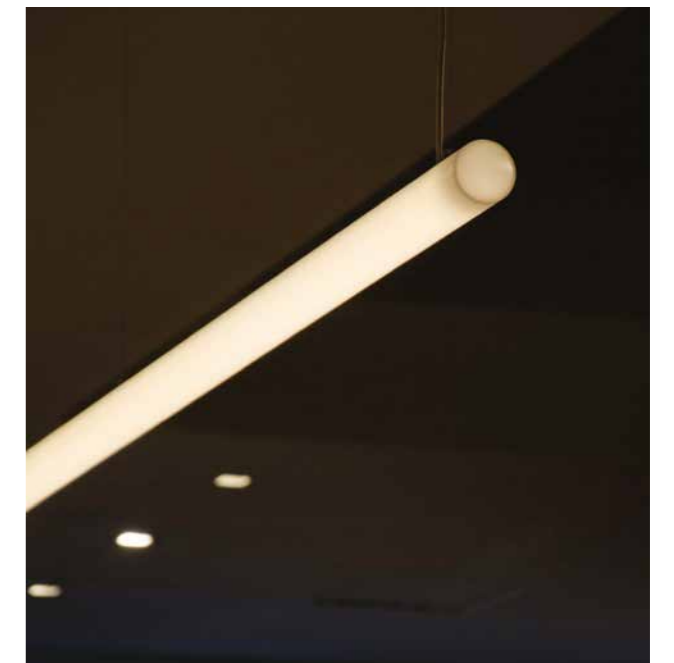

**iMdi**® **Hostel América del Sur**  
San Telmo

*Proyecto:* Carolina y Lucila Reich

*Año:* 2019

*Ubicación:* Chacabuco 718 (CABA, Argentina)

**Hostel América del Sur**  
San Telmo

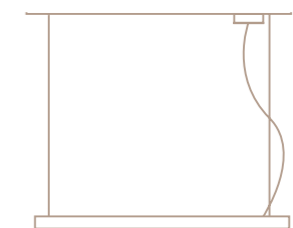

Puma colgante



Shade chica



**Amura Suites**  
Pinamar



**iMdi**® **Amura Suites**  
Pinamar

*Año:* 2019

*Ubicación:* Pinamar (Buenos Aires, Argentina)



HiHat velador translúcido

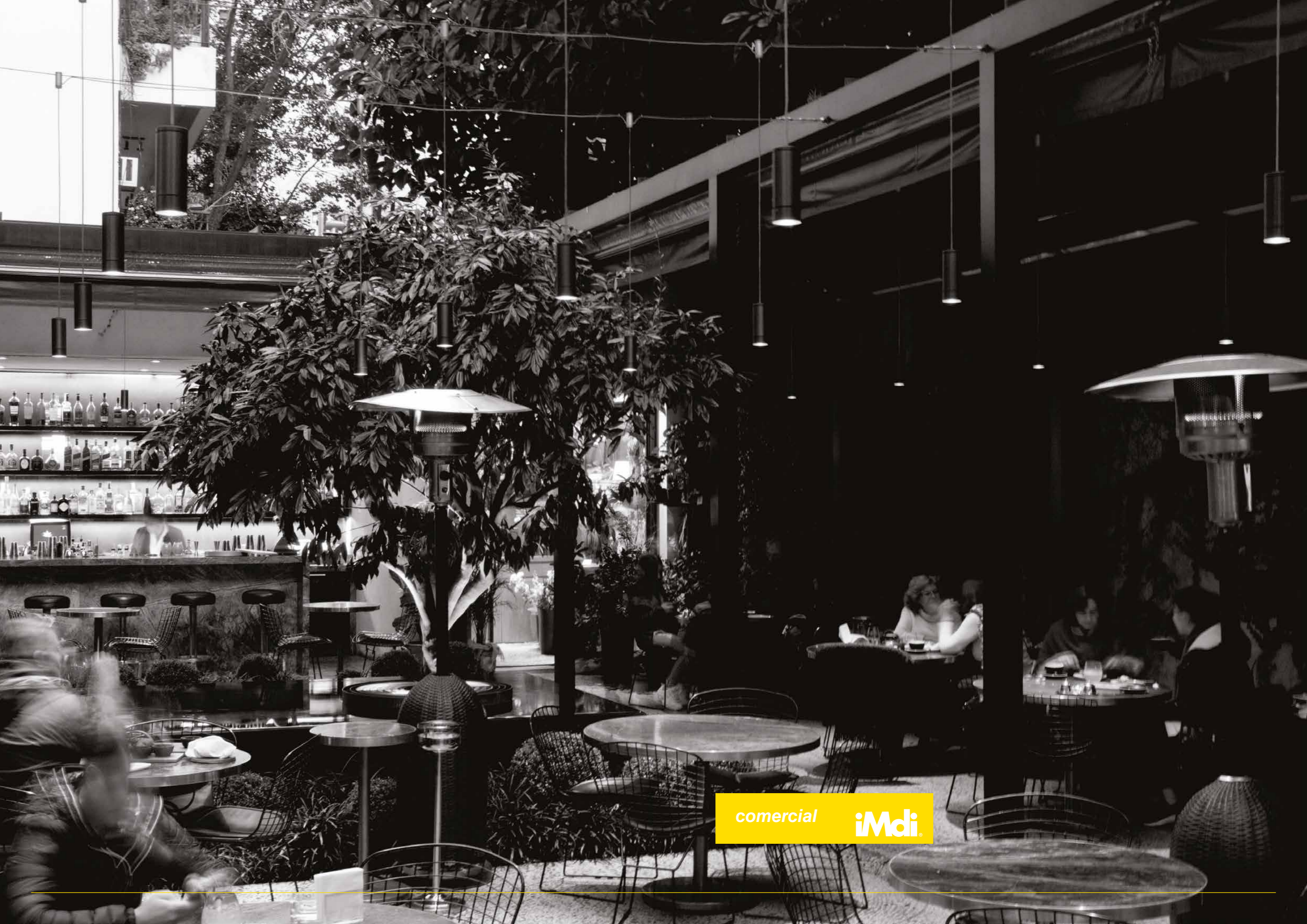

comercial

iMdi.



Piso Nueva  
CCK

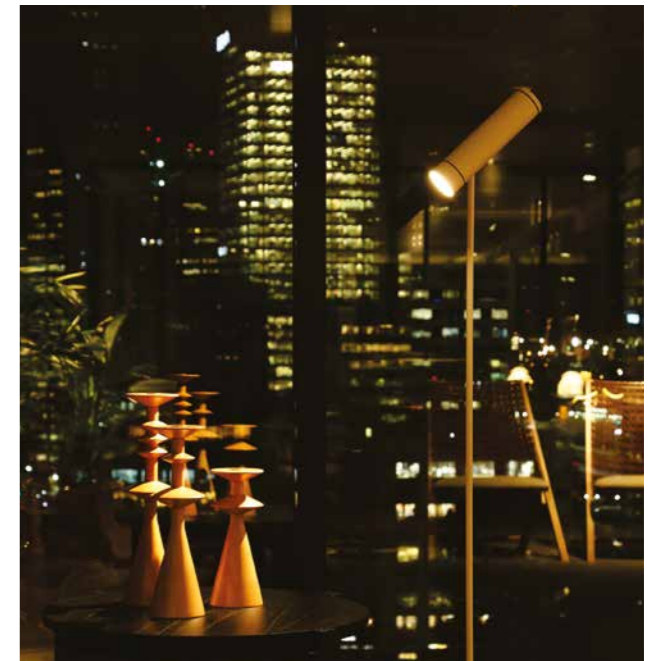

**iMdi**® Piso Nueva  
CCK

*Proyecto:* Equipo Sello Buen Diseño

*Año:* 2019

*Ubicación:* Sarmiento 151 (CABA, Argentina)



HiHat de pie med. traslúcida



HiHat de pie



Cavia de pie

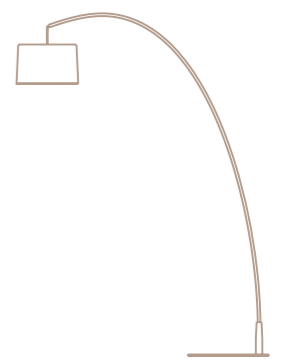

Arco de pie



Starbucks  
Nuñez

# iMdi® Starbucks Nuñez

Proyecto: Starbucks

Año: 2016

Ubicación: Juana Azurduy 2406 (CABA, Argentina)



HiHat diseño especial





**Casa Cavia**  
Palermo chico



**iMdi**® **Casa Cavia**  
Palermo chico

*Proyecto:* Kallos-Turin architects - London

*Año:* 2015

*Ubicación:* Cavia 2985 (CABA, Argentina)



Cavia colgante corta



**iMdi**® **YPF Full**  
Nordelta

*Proyecto:* Hampton-Rivoira arquitectos + Estudio Cabeza (interiores)  
*Idea y anteproyecto:* Fernando Piedrabuena  
*Desarrollo y proyecto:* Arq. Verónica Gilotau  
*Año:* 2011  
*Ubicación:* Av. del Lago (Tigre, Argentina)

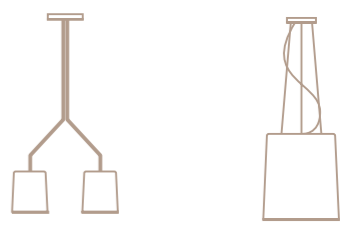

HiHat diseño especial    HiHat colgante grande

**YPF Full**  
Nordelta



Ninina Bakery  
MALBA

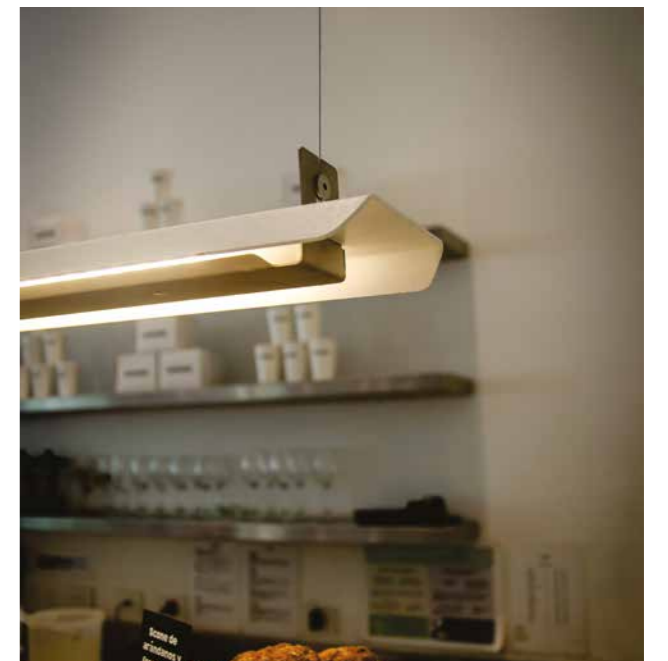

**iMdi**® Ninina Bakery  
MALBA

Proyecto: Estudio Verardo

Año: 2017

Ubicación: Av. Pres. Figueroa Alcorta 3415 (CABA, Argentina)

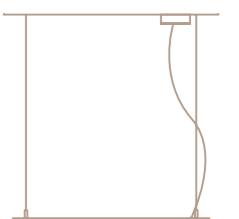

Aero colgante



McDonald's  
Olivos



**iMdi**® McDonald's  
Olivos

*Proyecto:* Equipo interno McDonald's  
*Año:* 2017  
*Ubicación:* Av. del Libertador 2803 (CABA, Argentina)



HiHat colgante chica HiHat colgante grande



**Malagrino**  
Olivos

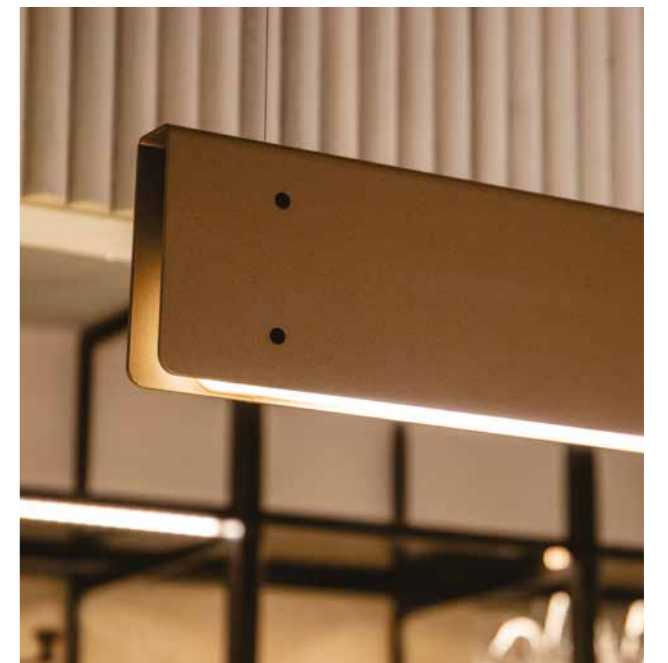

# iMdi® Malagrino Olivos

**Proyecto:** Nidolab

**Iluminadora:** Arq. Giuliana Nieva

**Año:** 2018

**Ubicación:** Corrientes 321 (CABA, Argentina)

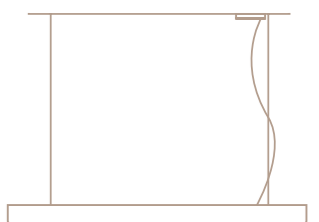

Masterline colgante

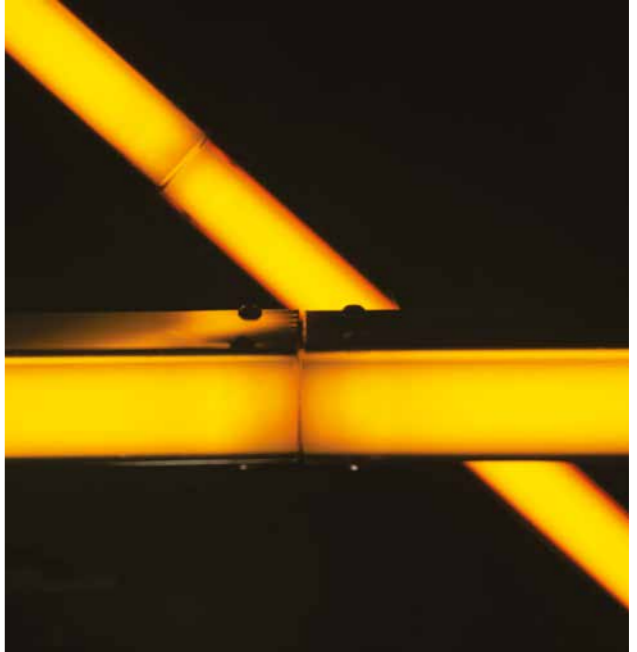

**iMdi** Sportline  
Lomas de Zamora

*Proyecto:* Dieguez-Fridman arquitectos  
*Iluminador:* Arq. Pablo Pizarro  
*Año:* 2017  
*Ubicación:* Laprida 350 (Lomas de Zamora, Argentina)

**Sportline**  
Lomas de Zamora

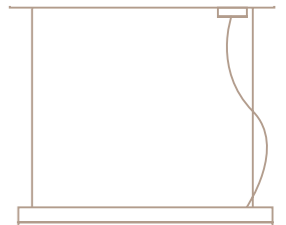

Diseño especial



Orilla  
Restaurant



**iMdi**® **Orilla**  
Restaurant

*Interiorismo:* Agustina Aguilar

*Año:* 2018

*Ubicación:* Montañeses 2585 (Buenos Aires, Argentina)



Cavia de pie



**iMdi**® **Sacro**  
Restaurant

*Proyecto:* Estudio The Wall

*Año:* 2019

*Ubicación:* Costa Rica 6038 (Buenos Aires, Argentina)

**Sacro**  
Restaurant



Cavia colgante corta



Cavia basculante corta





#HUERTACELEBRA

oficinas

iMdi.



**Tarjeta Naranja**  
Edificio corporativo Córdoba



**iMdi** **Tarjeta Naranja**  
Edificio corporativo Córdoba

*Proyecto:* Estudio AFT

*Año:* 2015

*Ubicación:* La Tablada 451 (Córdoba, Argentina)



HiHat de pie mediana



**iMdi**® **Estudio Galera**  
Oficina Cariló

*Proyecto:* Estudio Galera

*Año:* 2016

*Ubicación:* Castaño 234 (Cariló, Argentina)

**Estudio Galera**  
Oficina Cariló



HiHat colgante

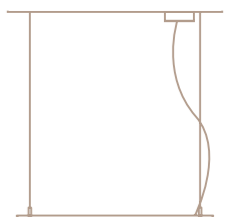

Aero colgante



**Talenter**  
Recepción / Oficinas

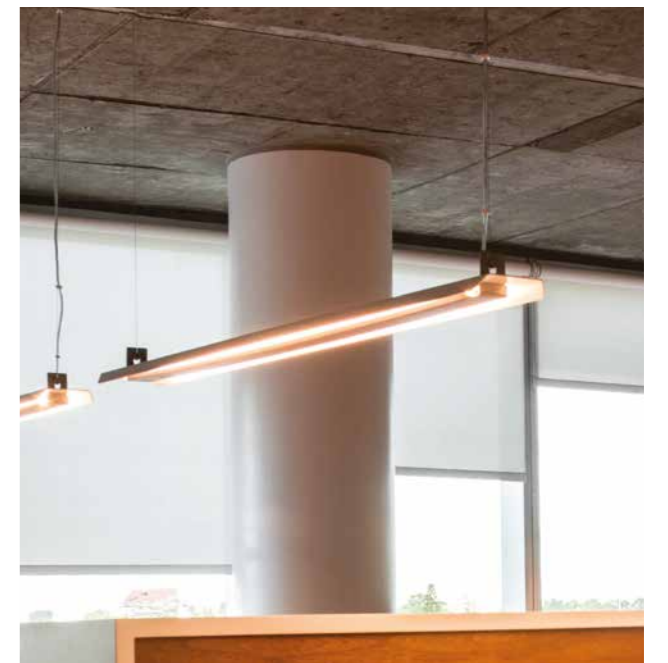

**iMdi® Talenter**  
Recepción / Oficinas

*Proyecto:* Arq. Carolina Reich + DI Martín Wolfson  
*Año:* 2015  
*Ubicación:* Av. Libertador 6810 (CABA, Argentina)



Charles de pie

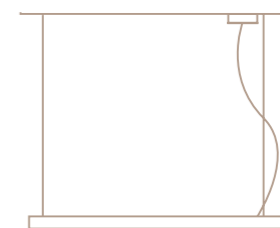

Puma colgante

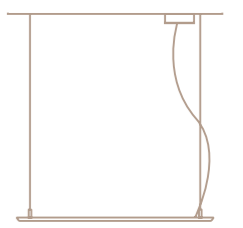

Aero colgante



**Talenter**  
Sala de reuniones / Comedor



**iMdi® Talenter**  
Sala de reuniones / Comedor

**Proyecto:** Arq. Carolina Reich + DI Martín Wolfson

**Año:** 2015

**Ubicación:** Av. Libertador 6810 (CABA, Argentina)



Cavia colgante corta



HiHat colgante grande



**iMdi**® **Talenter**  
Presidencia

*Proyecto:* Arq. Carolina Reich + DI Martín Wolfson  
*Año:* 2015  
*Ubicación:* Av. Libertador 6810 (CABA, Argentina)

**Talenter**  
Presidencia



Tokio escritorio

HiHat de pie mediana



I+D  
Oficinas

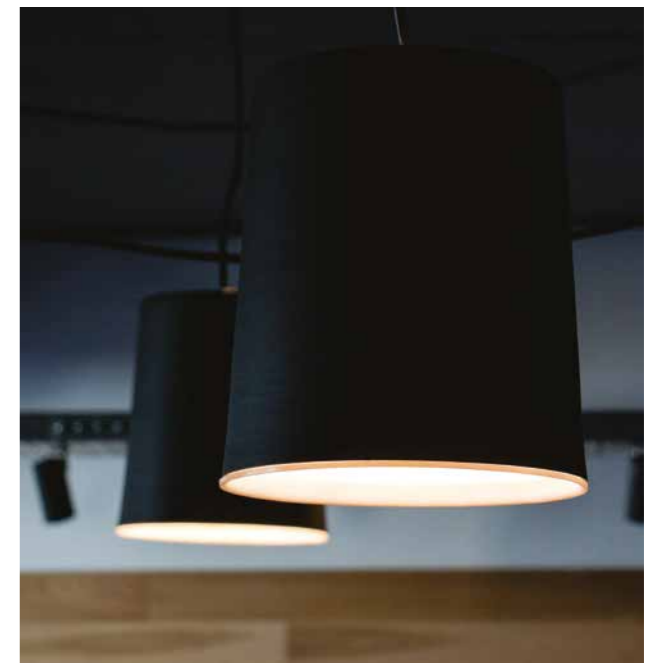

**iMdi**® I+D  
Oficinas

*Proyecto:* Jessica Bergman

*Año:* 2019

*Ubicación:* Belgrano (Buenos Aires, Argentina)



HiHat coltante chica



**iMdi**® Huerta  
Coworking

*Proyecto:* Lucía Lograsso

*Año:* 2019

*Ubicación:* Av. Dorrego 2133 (Buenos Aires, Argentina)

Huerta  
Coworking



Cavía basculante larga





**Mercado Libre**  
Buenos Aires



**iMdi** Mercado Libre  
Buenos Aires

*Proyecto:* Arq. Paula de Elía - Arq. Milagros Irastorza

*Iluminador:* Arturo Peruzotti

*Año:* 2019

*Ubicación:* Posta 4789 (Buenos Aires, Argentina)



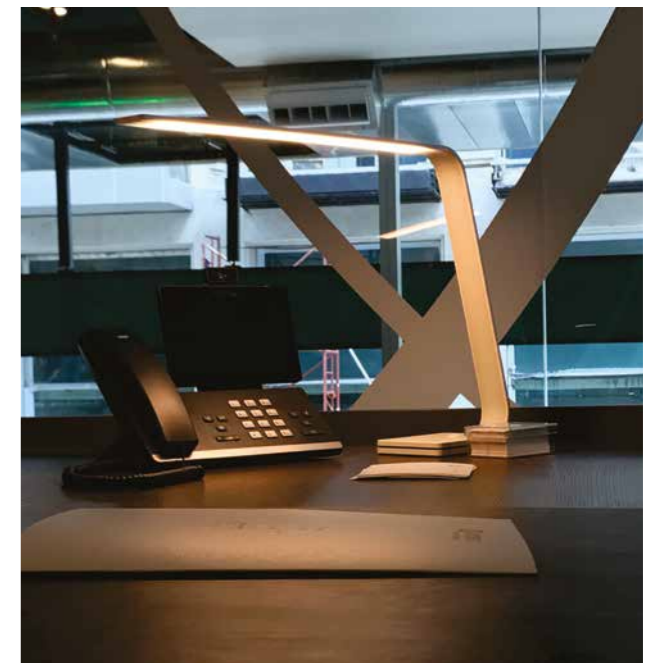

**iMdi** Universidad Siglo21  
Sede Al Río

*Interiorismo:* D.I. Marcelo Curtino + D.I. Martín Wolfson

*Año:* 2018

*Ubicación:* Av. Libertador 107 (Vicente López- Buenos Aires, Argentina)

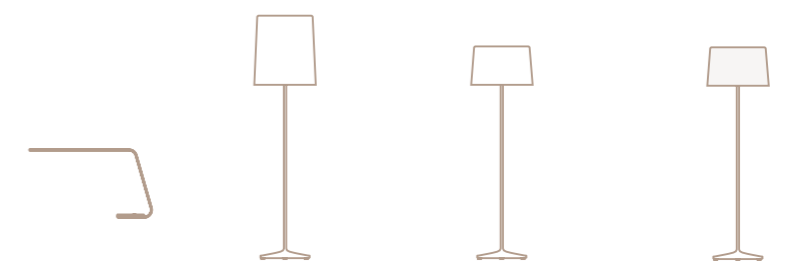

Tokio escritorio HiHat de pie grande HiHat de pie mediana HiHat de pie translúcida

Universidad Siglo21  
Sede Al Río



**WeWork**  
Buenos Aires

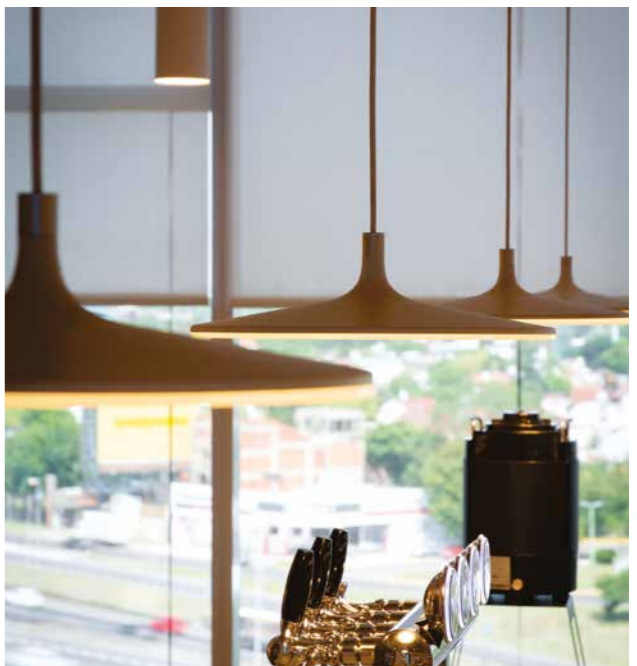

**iMdi**® **WeWork**  
Buenos Aires

*Proyecto:* Equipo de Diseño WeWork  
*Iluminadora:* María del Pilar Toro Ortiz  
*Año:* 2019  
*Ubicación:* Buenos Aires, Argentina

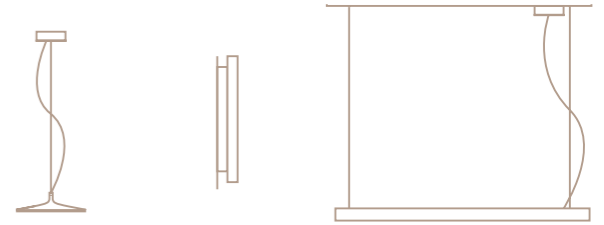

HiHat colgante    Puma aplique    Puma colgante



**Gire - RapiPago**  
Oficinas

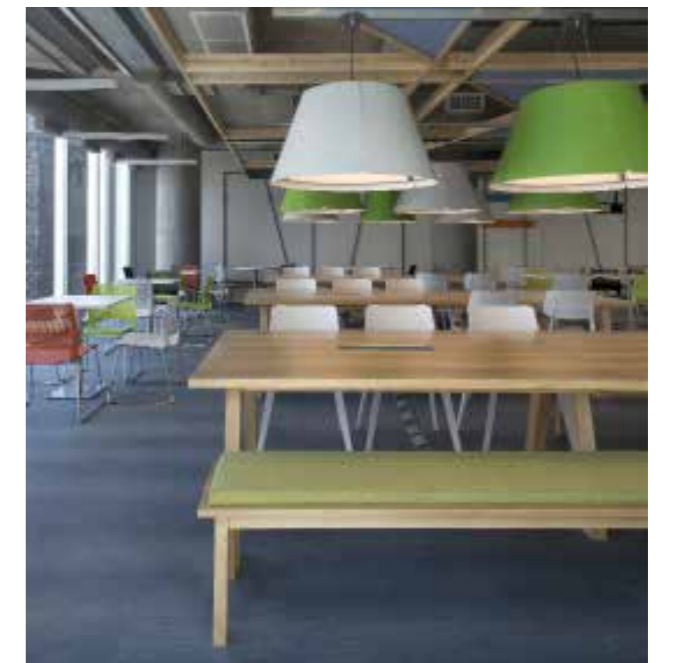

**iMdi**® **Gire - RapiPago**  
Oficinas

*Proyecto:* Rosellini

*Iluminador:* Pablo Pizarro

*Año:* 2018

*Ubicación:* Juan Domingo Perón 955 (CABA, Argentina)

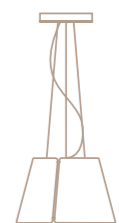

Shade chica

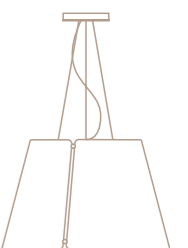

Shade grande



**Banco Santander**  
Casa Matriz



**iMdi**® **Banco Santander**  
Casa Matriz

*Proyecto:* Urgel-Penedo-Urgel

*Iluminador:* Pablo Pizarro

*Año:* 2019

*Ubicación:* Bartolomé Mitre 480 (CABA, Argentina)



Cavia especial



residencias

iMdi.



E. Martínez  
Casa



**iMdi**® E. Martínez  
Casa

*Interiorismo: Estudio Curado*

*Año: 2019*

*Ubicación: CABA, Argentina*



HiHat colgante



Charles de pie



**iMdi**® **Pachecho de Melo**  
Casa

*Interiorismo: Estudio Curado*

*Año: 2019*

*Ubicación: CABA, Argentina*

**Pachecho de Melo**  
Casa



Charles colgante





**Casa Kuvasz**  
Cariló



**iMdi** Casa Kuvasz  
Cariló

*Proyecto:* Estudio Galera

*Año:* 2016

*Ubicación:* Cariló (Buenos Aires, Argentina)



Cavia colgante corta especial    Cavia colgante larga



**El Faro**  
Departamento

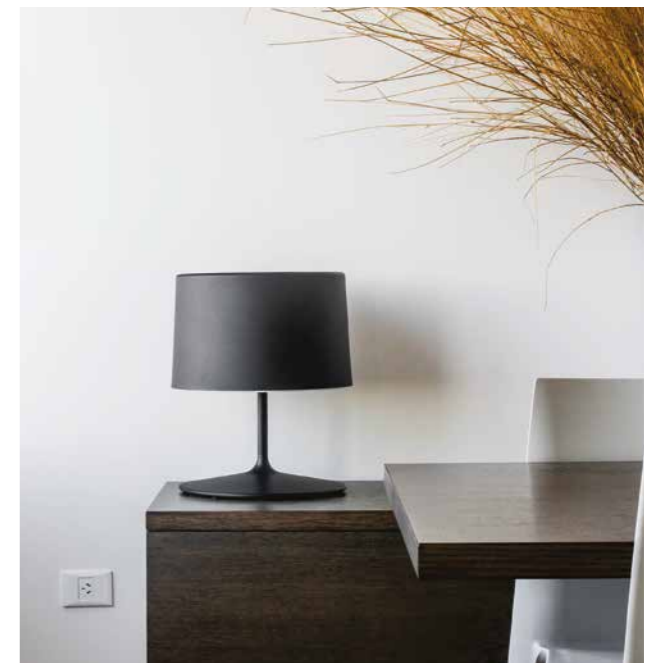
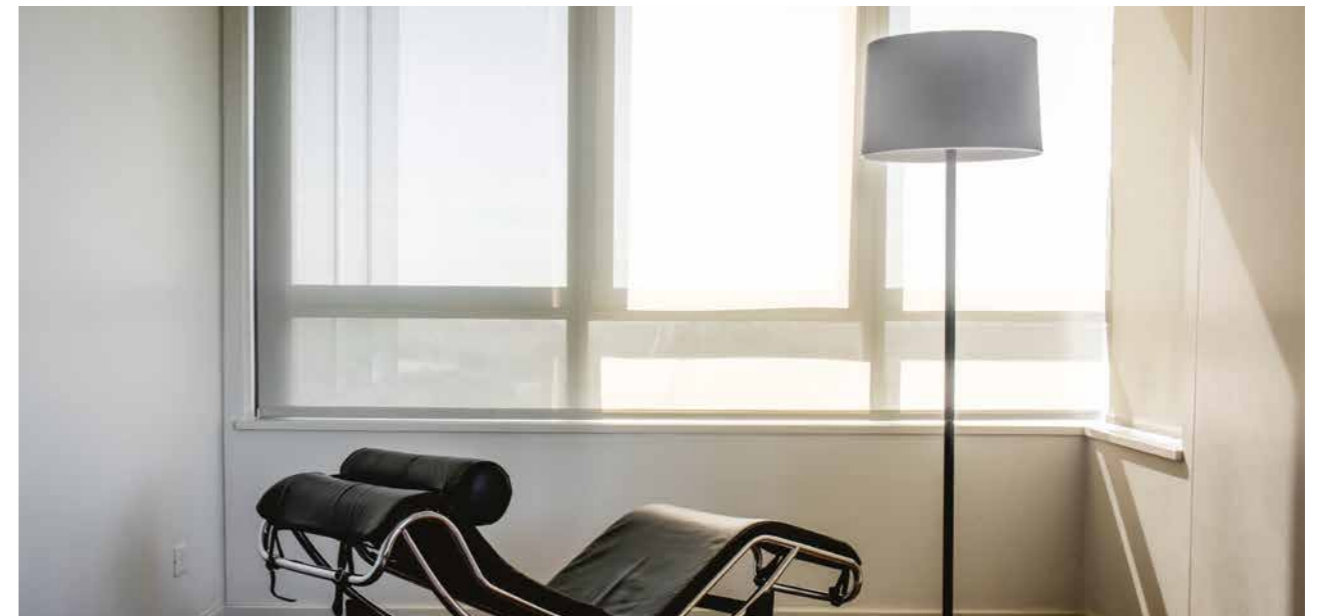

**iMdi**® **El Faro**  
Departamento

*Año: 2010*

*Ubicación: CABA, Argentina*



HiHat de mesa mediana



HiHat de mesa grande



HiHat de pie grande



HiHat de pie mediana



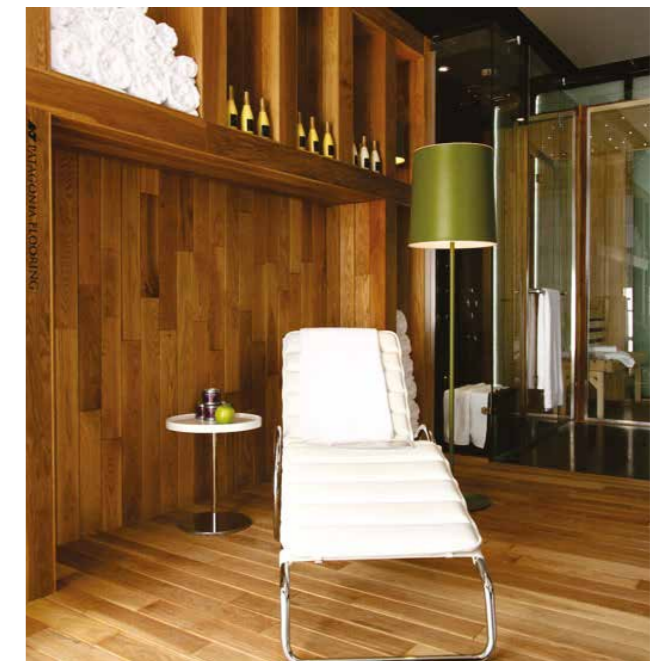

**iMdi** Casa FOA 2012  
Espacio 27 - Campi

Proyecto: Arq. Angélica Campi

Año: 2012

Ubicación: Av. Regimiento De Patricios 1000 (CABA, Argentina)



HiHat de pie grande



HiHat velador chico

Casa FOA 2012  
Espacio 27 - Campi

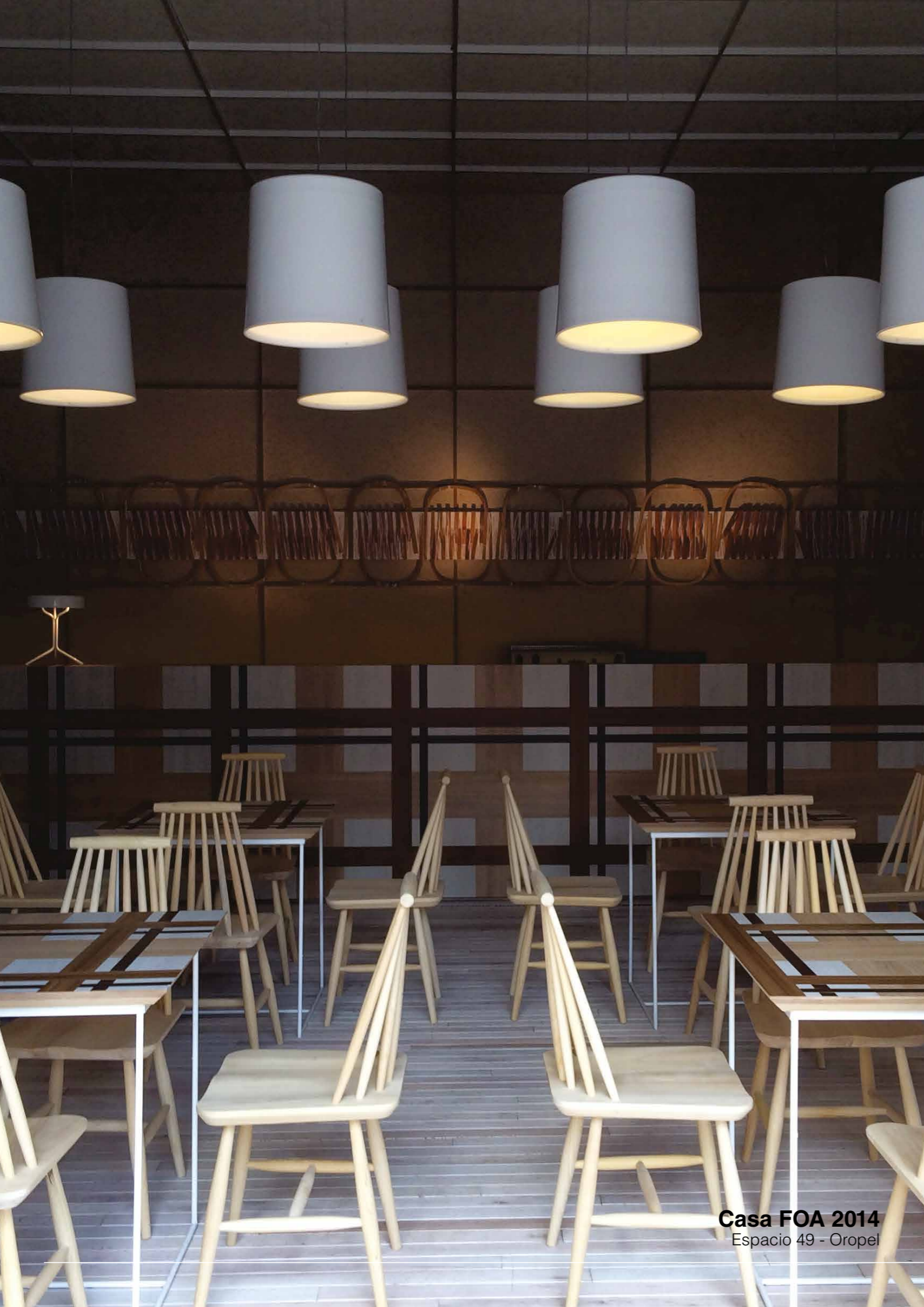

**Casa FOA 2014**  
Espacio 49 - Oropel



**iMdi** Casa FOA 2014  
Espacio 49 - Oropel

*Proyecto:* Arq. Julio Oropel

*Año:* 2014

*Ubicación:* Gorostiaga 1908 (CABA, Argentina)



HiHat colgante grande



**Casa FOA 2015**  
Espacio 36 - Costa Paz

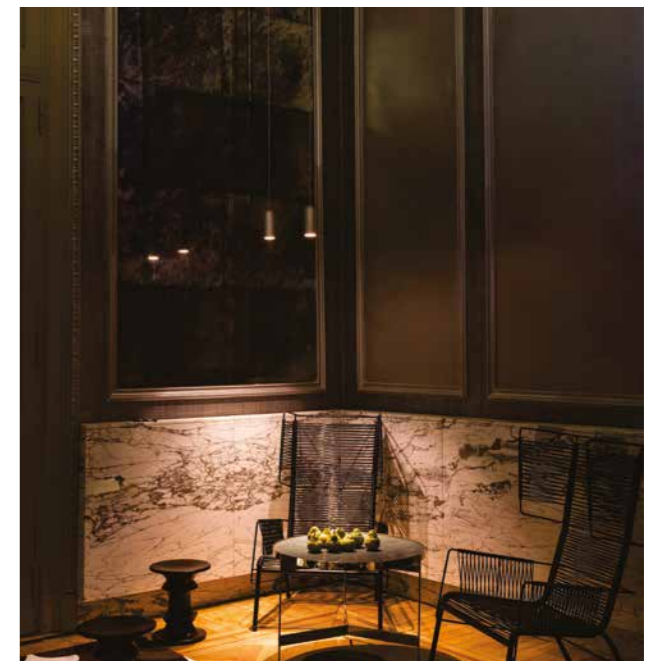

**iMdi** Casa FOA 2015  
Espacio 36 - Costa Paz

*Proyecto:* Matty Costa Paz

*Año:* 2015

*Ubicación:* Basalvbaso 1233 (CABA, Argentina)



Cavía colgante corta



**Casa FOA 2016**  
Espacio 15 - Oropel

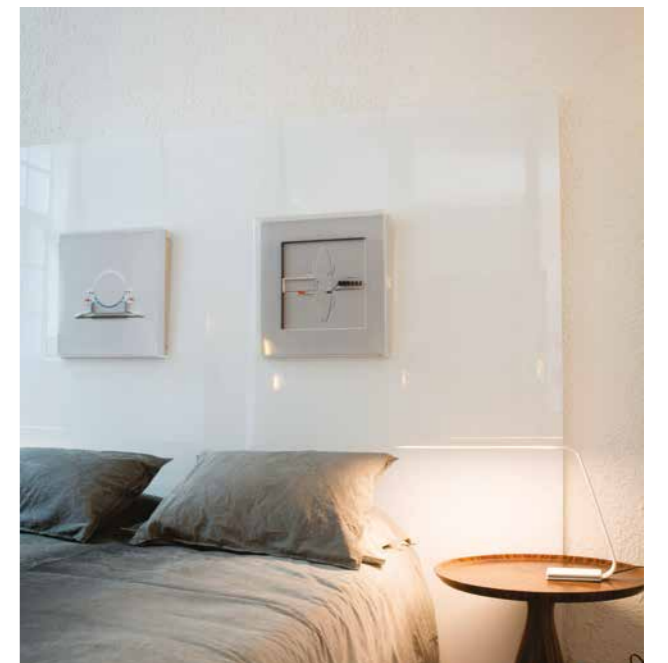

**iMdi** Casa FOA 2016  
Espacio 15 - Oropel

*Proyecto:* Arq. Julio Oropel

*Año:* 2016

*Ubicación:* José Antonio Cabrera 5653 (CABA, Argentina)



Tokio escritorio



**Casa FOA 2016**  
Espacio 18 - Campi



**iMdi**® **Casa FOA 2016**  
Espacio 18 - Campi

*Proyecto:* Arq. Angélica Campi

*Año:* 2016

*Ubicación:* José Antonio Cabrera 5653 (CABA, Argentina)

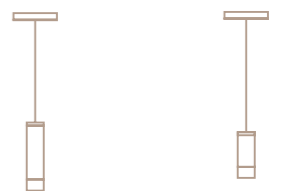

Cavía colgante larga    Cavía colgante corta





**Casa FOA 2017**  
Espacio 18 - Heredia Vecchia Milia



**iMdi** Casa FOA 2017  
Espacio 18 - Heredia Vecchia Milia

*Proyecto:* Heredia - Vecchia - Milia Arquitectos

*Año:* 2017

*Ubicación:* Av. Luís María Campos 1336 (CABA, Argentina)

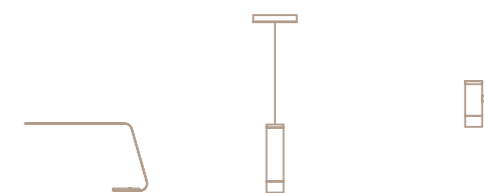

Tokio escritorio Cavia aplique larga Cavia aplique corto



**Casa FOA 2017**  
Espacio 40 - González Zuelgaray



**iMdi** Casa FOA 2017  
Espacio 40 - González Zuelgaray

*Proyecto:* Arq. María Beatriz González Zuelgaray

*Año:* 2017

*Ubicación:* Av. Luís María Campos 1336 (CABA, Argentina)



HiHat colgante



**Casa FOA 2017**  
Espacio 19 - PQR



**iMdi** Casa FOA 2017  
Espacio 19 - PQR

Proyecto: Estudio PQR  
Año: 2017  
Ubicación: Av. Luís María Campos 1336 (CABA, Argentina)



Cavia spot corto      Diseño especial      Cavia colgante larga



**Casa FOA 2018**  
Espacio 11 - PLATZ Arq.



**iMdi** Casa FOA 2018  
Espacio 11 - PLATZ Arq.

*Proyecto:* PLATZ Arq.

*Año:* 2018

*Ubicación:* Pareja 3670 (CABA, Argentina)

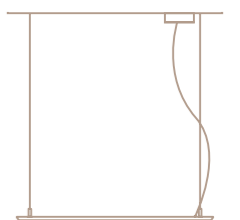

Aero colgante



Casa FOA 2018  
Espacio 32 - Melamed



**iMdi** Casa FOA 2018  
Espacio 32 - Melamed

Proyecto: Arq. Viviana Melamed  
Año: 2018  
Ubicación: Pareja 3670 (CABA, Argentina)



Cavia spot corto Cavia aplique largo



**Casa FOA 2019**  
Espacio 55 - PLATZ Arq.



**iMdi** Casa FOA 2019  
Espacio 55 - PLATZ Arq.

*Proyecto:* PLATZ Arq.

*Año:* 2019

*Ubicación:* Circulo Militar Olivos - Av. Libertador 2100 (Olivos, Argentina)



Shade chica



Shade grande

**Concepto y Diseño**

Equipo de Diseño iMdi  
D.I. Guido Martín Ventura

**Fotografía**

Mariela Rivas  
Rodrigo Mendoza  
Diego Medina  
Lucía Lo Grasso

**Rendering fotorealista**

JW Renders

**Rendering fotorealista**

D.I. Axel Mazzeo

Abril 2020. Buenos Aires, Argentina.  
iMdi®



**WOLFRE S.A.**  
Céspedes 3635 C1427EAC  
CABA, Argentina

tel [54 11] 4551-9734  
info@imdi.com.ar  
www.imdi.com.ar



2020. Buenos Aires, Argentina.  
iMdi®